



AIR HANDLING UNIT



*Smartwise Innovations...
Towards Green, Quality & Reliability Solutions*

 **Smartech**

SMT SERIES

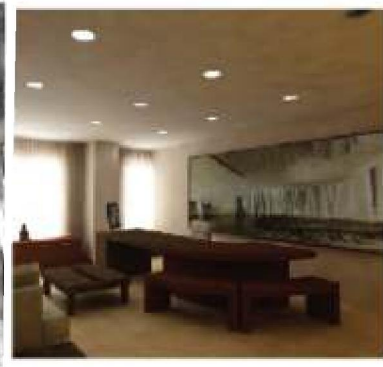

INTRODUCTION

This series of Air Handling Units was developed by a group of industry engineers, each of them with over 20 years of experience in the design, manufacturing, installation and service of electric chillers, packaged air-conditioners, split air-conditioners, fancoils, air handling units, and related products.

- The Group is fully committed to innovative design, new and advance technology, value engineering and to provide expert personalized service to architects, consulting engineers, developers, building owners and contractors.
- The company's ability and courage to utilize and adopt latest technology, combined with fullest personalized assistance, has enabled the company to provide architects, consultants and developers various customized solutions to their various demanding application requirements.
- The company has the unique expertise and experience to custom design and fabricates equipment for installations in marine and corrosive environment, explosive and hazardous environment, low noise environment and any other special application needs!

Smartwise Innovations...

Towards Green. Quality & Reliability Solutions

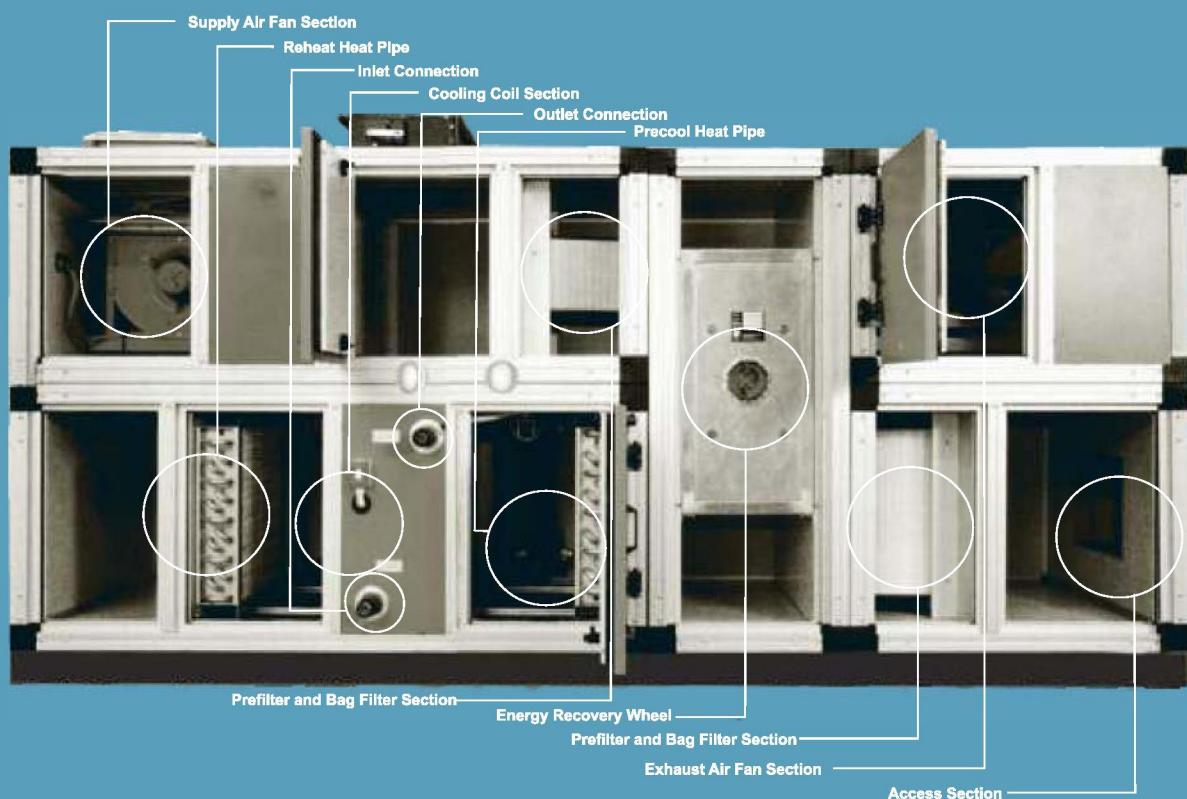



AIR HANDLING UNIT

GENERAL DESCRIPTION

This series of Central Station Air Handling Units is the product from culmination of over 20 years experience in the design, applications and manufacturing of Central Station Air Handling Units, and by incorporating the latest and advance materials and components into its construction.

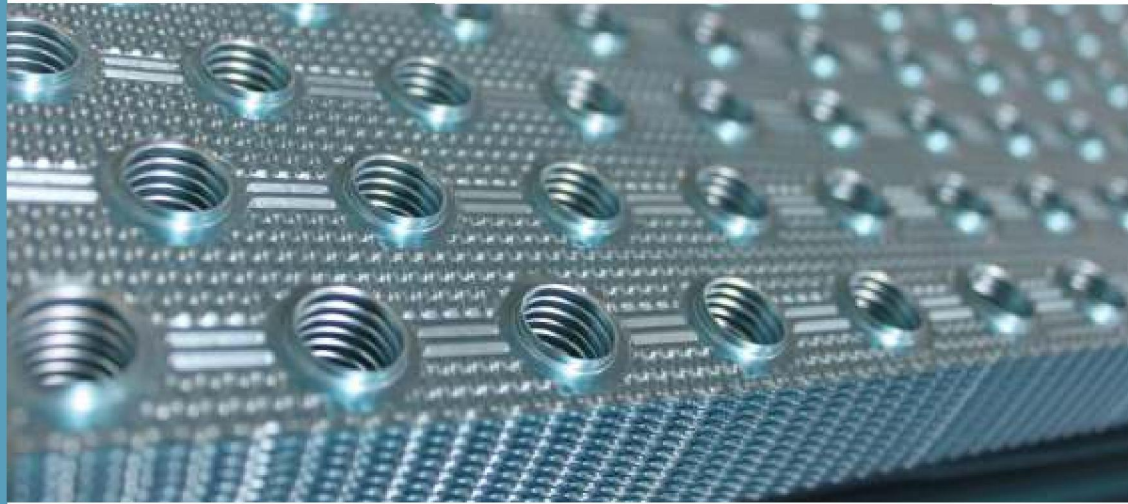

THE SERIES OFFERS THE FOLLOWING OPTIONS AND FEATURES

- Our standard design is using **Double-Wall Insulated Casing**, Double wall insulated casing can be of different thicknesses (1", 2", 3", 4"), insulated with different insulation materials (polyurethane, fibre-glass, rockwool) and internally lined with plain or perforated GI sheet; selected to meet any fire protection requirement, thermal insulation requirement, acoustic attenuation, noise-breakout requirement and specific environmental requirement.
- A wide range of standard model sizes to handle air flowrates from **1,200 cfm to 60,000 cfm**. Units that require to handle higher than 60,000 cfm can be custom engineered and manufactured to suit any application requirement.
- A choice of selecting either single-zone horizontal type Air-handling unit single-zone vertical type Air-handling unit or multizone Air-handling unit, provides flexibility to suit any installation or application requirements.
- A wide choice of accessory sections such as filter sections, diffuser sections, mixing box sections, humidifier sections, face & bypass damper sections, Heating sections, Energy wheels heat recovery sections, fan only sections, cooling coils sections, silencer sections to meet any Air-conditioning, Air-handling or filtration requirements.
- Different types of Blower fans can be selected such as **Forward Curved Fans, Backward Inclined Flat Blades Fans, Backward Inclined Airfoil Blades Fans, Plug Fans**, provide flexibility in selecting a fan to meet a particular Air flowrates, static pressure losses and efficiency requirements.

THE SERIES OFFERS THE FOLLOWING OPTIONS AND FEATURES *cont'd*

- Computer optimised selection of coils to meet any heating or cooling requirements.
- As a standard offering, complete assembly of fan, motor and drive package is internally mounted and resiliently isolated from unit casing by either rubber or spring vibration isolators. The complete assembly of Blower fan, motor and drive package is statically and dynamically balanced to reduce vibration and prolong motor bearings and belts life. Externally mounted motor and drive package and externally mounted spring vibration isolators can also be offered whenever required.
- Factory installed and wired frequency inverter to vary motor speed, for efficient variable air-volume control and to reduce energy cost.
- Removable access panels or hinged access panels with quick latches to facilitate accessibility to internal parts and ease of servicing and troubleshooting.
- Weather proof casing construction with “pitched” roof for outdoor installation is available.

Nomenclature



SMT	SMT SERIES
AH	AIR HANDLING UNIT
2D	CASING PANEL TYPE 1S - 1" thick Single-skinned 1D - 1" thick, Double - wall 2D - 2" thick, Double - wall 1DT - 1" thick, Thermal Break 2DT - 2" thick, Thermal Break
100	NOMINAL AIR FLOWRATES (X 100 CFMS)
H	STRUCTURAL PATTERN OF UNIT H - SINGLE ZONE HORIZONTAL V - SINGLE ZONE VERTICAL M - MULTIZONE
AF	BLOWER TYPE AF - AIRFOIL FAN BF - BACKWARD FLAT BLADE FAN FC - FORWARD CURVE FAN PF - PLUG FAN
I	BLOWER CONSTRUCTION CLASS II - CLASS II FAN, MEDIUM PRESSURE III - CLASS III FAN, HIGH PRESSURE



MECHANICAL SPECIFICATIONS AND FEATURES

A. UNIT CASING

THE CASING FRAMEWORK is constructed from extruded Aluminum structural section, locked together by cast Aluminum or rigid nylon corner joining modules, to form a rigid framework, for sizes up to 500. For sizes larger than size 500, the unit shall be custom-built with the casing framework constructed from die-formed steel channels bolted together by steel corner joining lugs, to form a rigid framework.

Two sizes of extruded Aluminum Structural members and corner joining modules are used to construct the casing for the different sizes of air-handling units and accessory sections.

I) For Size 24 to Size 160

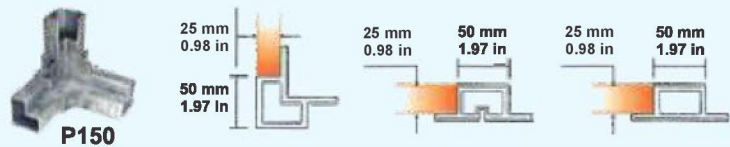

II) For Size 210 to Size 500

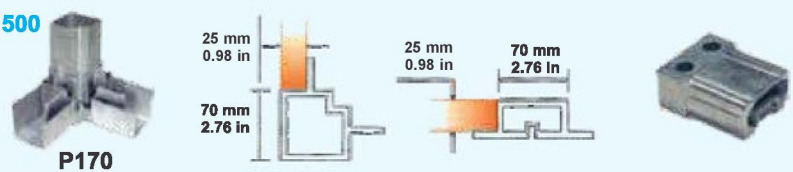

III) Thermal Break for 1" Panel

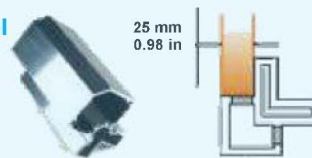

IV) Thermal Break for 2" Panel



THE CASING EXTERNAL PANELS are of cold-rolled steel sheet construction, degreased, bonderised and coated with oven-baked epoxy powder to provide an esthetically finished coating, to prevent corrosion and rust. All joints and mating surfaces are heavily gasketted and sealed for air tightness.

THE SINGLE-SKINNED CASING PANELS are internally lined with 1" / 1½ lb density mat-faced fibreglass which meets NFPA-90A requirements and securely held on to casing by water-based adhesive and insulation pins, to prevent fibreglass erosion.



A. UNIT CASING *cont'd*

THE DOUBLE-WALL CASING PANELS have sandwiched insulation between external heavy gauge steel sheet and internal GI liner, to form a durable rigid casing, capable to withstand high working pressures and impact forces. The insulation materials can be fibreglass of different thicknesses and densities, rockwool or formed-in-place polyurethane insulation, selected to meet required thermal insulation and acoustic attenuation requirements. The polyurethane insulation has "k" value of 0.02 watts/m²c and density of 40 kg/m³. Perforated internal GI liner with 40% open area is available for good sound attenuation properties and is provided for the Fan Section. With double-wall construction, it is easy to clean the inner surfaces to reduce risk of dirt and bacteria contamination. There is no erosion of internal insulation material which can contaminate the air stream. The double-wall construction unit is ideal for clean room application such as Hospital, operating theater, electronic factory, food processing and pharmaceutical factories.



Backward airfoil blower

B. BLOWER FAN SECTION

FANS

Different types and construction class of fans can be selected to meet a particular application requirements. Fan type consists of forward curve fans, Backward inclined flat blades fans, Backward inclined airfoil fans and plug fans. All fans used are of either Class II or Class III construction. All fans are constructed and tested in accordance to AMCA 210 - 85 standard. All fan wheels are statically and dynamically balanced to ISO1940 and AMCA 204-G2.5 standards.



Forward Curve Fan



Forward Curve Centrifugal Fan

FAN BEARINGS

All fan bearings are of heavy duty pillow block construction, with deep groove ball type sealed at both sides, self aligning with an eccentric locking collar for clamping onto the shaft and is mounted in rubber Housing. Although the bearings are prelubricated for life and maintenance-free under normal operating condition, periodic inspection and relubrication is recommended whenever necessary. For relubrication, it is recommended to use lithium based grease suitable for all temperatures within the operating limits. Bearings are selected for average 200,000 operating hours.



Plug Fan

MECHANICAL SPECIFICATIONS AND FEATURES *cont'd*

B. BLOWER FAN SECTION *cont'd*

SHAFT

Shafts are manufactured from **C45 carbon steel** with keyways for mounting of fan pulley. All dimensional tolerances of the shaft are fully checked to ensure a precision fit and then coated with an anticorrosion varnish after assembly.



Vibration Isolation

VIBRATION ISOLATION

Complete fan, motor and drive assembly is mounted on a rigid steel base frame and isolated from unit casing by Rubber isolators or spring vibration isolators. The blower fan discharge outlet is connected by a fire retardant flexible canvas connector to the fan section outlet duct collar to further reduce vibration of the unit.

C. COIL SECTION

For single-zone horizontal type unit, offers a combined fan & coil Section for sizes up to 260; in addition to separate fan only section and Coil Section from Size 300 to Size 500. For single zone vertical type unit, a combined fan & coil Section is available from size 24 to size 82; above which fan & coil Sections are constructed and shipped separately for field joining together as a single unit, for size up to 160. Typical coil space is 15 inches width, adequate to accommodate a 8 Rows deep cooling coils and a 2 inches thick filter rack. Extended coil space can be provided as option, to accommodate preheat coils, reheat coils, two-stage cooling coils and even a humidifier section.

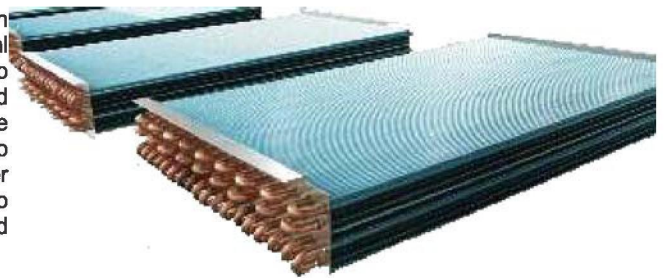

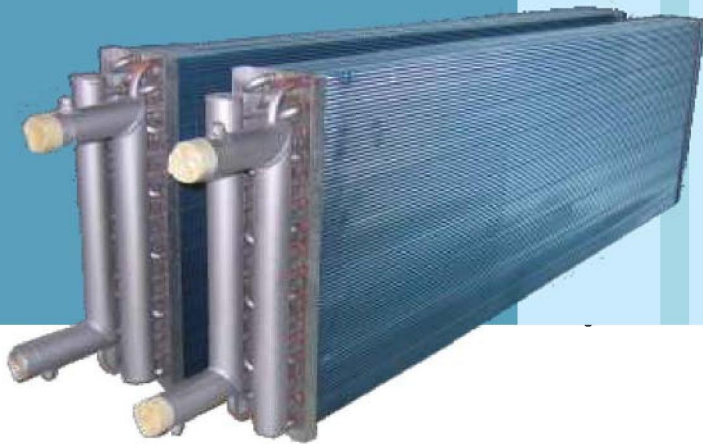

WATER COILS

All drainable water coils for both cooling and heating are constructed from 1/2" OD copper tubes, in staggered rows, mechanically expanded into die-formed corrugated Hydrophilic Aluminum fins; spaced at either 8, 10, 12 or 14 fins per inch and with rippled edge. Drainable water coils are offered from 1 Row deep to maximum 8 Rows deep. All drainable water-coils are pressurized to minimum 350 psig and leak tested under water and are suitable for design working pressures up to 250 psig at 200°F. Drainable water coil headers are constructed from thick wall carbon steel pipe with threaded connections. Copper pipe headers with brass connectors are available as option.

DIRECT EXPANSION COILS

Direct expansion coils are offered in both 3/8" OD copper tubes and 1/2" OD copper tubes, in staggered rows, mechanically expanded into die-formed corrugated Hydrophilic Aluminum fins; spaced at either 8, 10, 12 or 14 fins per inch, and with rippled edges. All coils are computer selected to meet specified performance and circuited to optimize performance and to reduce water or refrigerant side pressure drops. Coil casing is constructed from **heavy gauge galvanised steel**, with option available for Aluminum or stainless steel casing. The following types of coils are also available:

- Copper fins or tinned copper fins coils
- Anti-corrosion ADSIL coated coils
- Coils used as air-cooled condensers



MECHANICAL SPECIFICATIONS AND FEATURES

cont'd

DRAIN PAN

The drain pan is of double-wall galvanised steel construction with sandwiched fibre-glass insulation between the inner liner and the heavy gauge external galvanised steel casing. The v-shape construction enable condensate to collect at the lowest part of drain pan and drains out at both sides of the units, through a threaded pipe condensate connectors. The inner galvanised steel liner is coated with mastic compound to protect against corrosion. Stainless steel drain pan is available as an option.

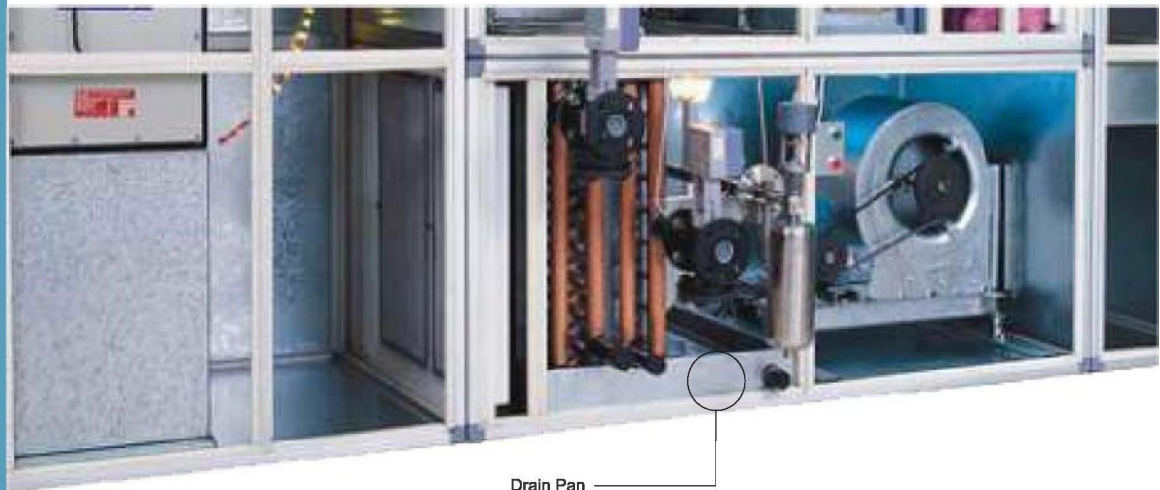

D. TYPICAL ACCESSORY SECTIONS AND ACCESSORIES

The face and bypass dampers offers modulation for air off coil temperatures. The opposed dampers vary the volumes of air through the cooling coil by bypassing some return air until the final air off coil temperature is attained. with 100% bypass, some temperature rise of the air passing through the unit will be experienced due to heat gain from radiation, convection and leakage.

THE FACE AND BYPASS DAMPER SECTION

The external face & bypass dampers is designed to bypass up to 100% return air and a full face coil is used. Internal face and bypass dampers section is used when the unit has height limitation; in this case, a reduced face area coil is used.

MECHANICAL SPECIFICATIONS AND FEATURES

cont'd

MIXING BOX SECTION

Two sets of dampers are interconnected together to modulate the amount of Fresh Air versus the Return Air and for efficient mixing of Fresh Air and Return air. The two sets of dampers can be connected to motorized actuators.

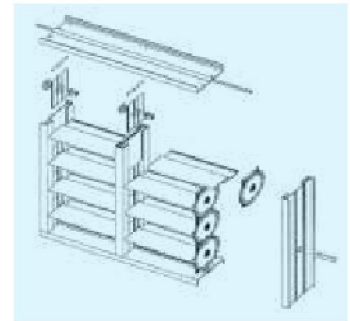

VOLUME CONTROL DAMPERS

Volume control dampers are important components used in the Face & Bypass section and Mixing Box section. To ensure effective and precise control of air flowrates which indirectly control or modulate the air temperatures, SMT Series uses a patented superior system of dampers which also has a low static pressure loss and a low air-borne noise as it varies the air flowrates through its blades. This system has movement gear coupled to each blade to ensure smooth, reliable and synchronized movement of the blades. The blades are constructed from extruded Aluminum and spaced at 80/100 mm apart. The edge of the blades has thermoplastic rubber gasket to ensure low air leakage rate or tightness when dampers are fully closed. The frame is also constructed from extruded Aluminum section to ensure light weight and rigid construction.



FREQUENCY INVERTERS

For variable-air-volume control, frequency inverter can be fitted and wired to fan motor to vary its speed of rotation in response to system Air flow requirement, thus giving optimum energy saving. The frequency inverter is mounted in a recessed compartment within the fan sections. The frequency inverter can be supplied with EMC filters and Auto-Bypass starting in case of inverter failure.

MECHANICAL SPECIFICATIONS AND FEATURES

cont'd

D. TYPICAL ACCESSORY SECTIONS AND ACCESSORIES cont'd

FILTERS SECTIONS

Various filter sections are available to house and hold different types of filters such as 2" flat filters, bag filters, HEPA filters, auto-roll filters, cartridge filters, carbon filters.

Different types of filter holding frames such as for front loading type or side loading type can be provided as per requirement. The angle filter section is design to increase filter face area, to reduce face velocity through the filter and is suitable for 2" pleated or flat filters.



PRIMARY FILTER

- To trap large particles
- To prolong the life of higher efficiency filters
- Available in disposable or washable type

SECONDARY FILTER

- To trap fine particles that are not filtered by primary filters
- Generally available in three efficiencies: 60 - 65%, 80 - 85% and 90 - 95%



AUTO ROLL FILTER

- Automatic renewable media air filter
- Act as pre-filtration for air conditioning system

SEMI-HEPA, HEPA / ULPA FILTERS

- Specially designed for areas requiring high level of cleanliness
- Widely used in semiconductor, pharmaceutical, glove and food industry
- Available in a wide range of efficiencies 95%@0.3um to 99.999995%@0.1- 0.2um.



CHEMICAL & CARBON FILTERS

- Effective for controlling odours and noxious vapours range
- Use to control corrosive gasses such as SOx1, H2S, NOx



COMBINATION FILTER MIXING BOX

The combination filter Mixing Box incorporates a two inch angle filter section within the Mixing Box Section to save on space. The 2" filters can be easily withdrawn through the side access door for cleaning or replacement.

SILENCER SECTION

Factory fabricated section complete with silencer splitters housed within the insulated casing space can be provided. The Silencer splitters are constructed from perforated galvanized steel sheets which are then filled with sound absorbing material, effectively reduce noise as the air passes through the splitters. Silencer sections are usually installed at either upstream or downstream of the blower fan section.



Silencer section

DIFFUSER SECTION

This section is typically installed between coil and fan section when blower fans is discharging onto the coil, to ensure uniform air flow velocity through the cooling coil for optimum cooling performance and to prevent excessive moisture carry-over. It is also installed between filter section and blower fan discharge, and between silencer section and Blower fan discharge.

CUSTOM-BUILT SECTIONS

Custom built sections are available to house heat recovery energy exchangers, run around heat recovery coils, silencers, humidifier, moisture eliminators, electric heaters, hot water preheat and reheat coils, ionizer. Heat pipes for energy recovery, desiccant dehumidifier and air blender.

MECHANICAL SPECIFICATIONS AND FEATURES

cont'd

D. TYPICAL ACCESSORY SECTIONS AND ACCESSORIES *cont'd*

HUMIDIFIER WITH MOISTURE ELIMINATOR SECTION

Factory can provide a Humidifier Section for either factory installed piping manifold for water spray humidifier piping manifold or piping manifold steam spray humidifier piping manifold. The source of water or steam including accessory fittings shall be field provided and installed by customer. Alternatively, factory can also supply bare humidifier section for field installed package humidifier system.

Moisture eliminator can be factory provided and installed downstream of humidifier to remove droplets of water which might be entrained in the air stream. The moisture eliminator can be constructed with blades and casing frame made from either extruded Aluminum or extruded polypropylene.

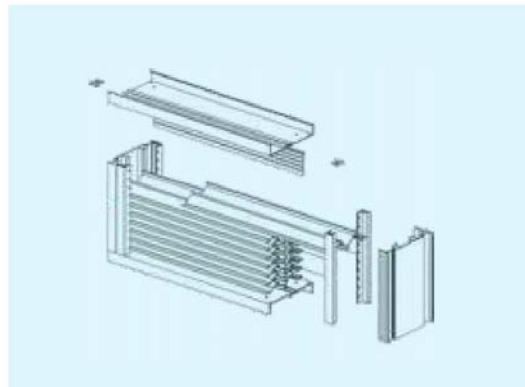

REHEATING WITH COMPRESORIZED DX SYSTEM

In order to lower the relative humidity of a conditioned space, the low temperature off coil air stream after passing through the main cooling coil, needs to be reheated before the dehumidified air enters the conditioned space. To lower the cost of reheating, especially by electric reheat, reheating by compressorized DX System should be considered. In this case, a suitably sized evaporator is selected and placed upstream of the main chilled water dehumidification coil for pre-cooling; while another suitably sized condenser coil, for reheating. The evaporator coil and condenser coil are connected by copper refrigerant pipes with expansion valves, filter drier, suction accumulator and other refrigerant control accessories, to one or more compressors. All these components are factory fitted, run tested and wired within the Air handling unit. the amount of reheating and pre-cooling can be modulated and controlled by a humidistat.

In a particular application, 3 nos of 3HP compressors were selected. At full load, the compressors provide a total of 115,000 Btu/hr of pre-cooling, with compressor input power of 6.8 kW. The heat rejection capacity or reheat kW = $6.8\text{kW} + (115000 / 3415) = 6.8\text{kW} + 33.7\text{kW} = 40.5\text{kW}$.

In other words, with 6.8 kW input, one can achieve 40.5 kW output for reheating and another 33.7 kW of pre-cooling. This is equivalent to heating C.O.P. of $40.5 / 6.8 = 6.0$.

In addition, one gets free cooling capacity of 115,000 Btu/hr. This will reduce the chiller loading by $115000 / 12000 = 9.6$ R.tons. Assuming, the chiller average kW/ton is 0.65, then this is equivalent to a potential reduction in chiller kW input of $0.65 \times 9.6 = 6.24\text{kW}$.

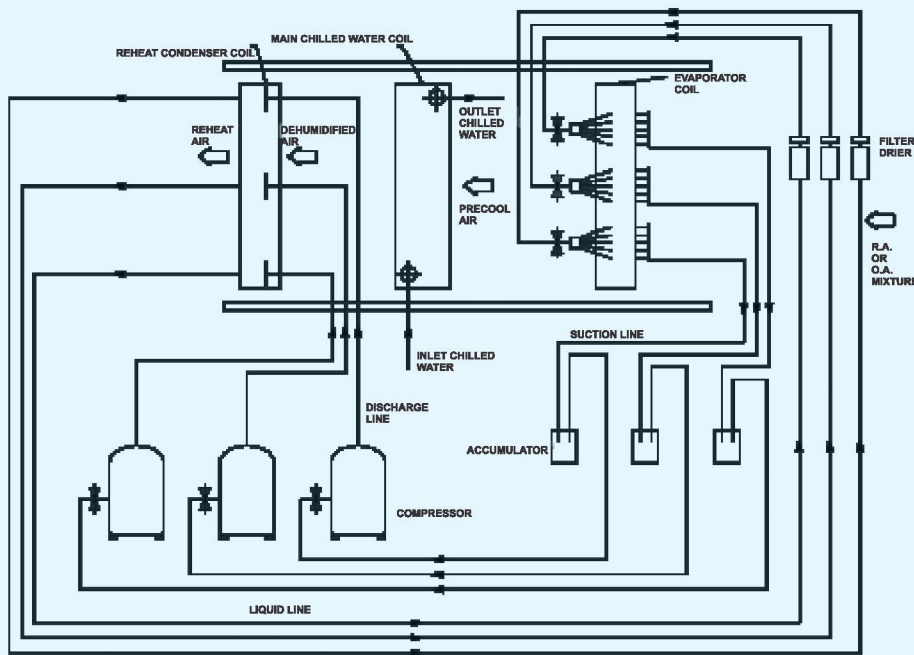

SCHEMATIC DIAGRAM FOR 3 COMPRESSORS DX REHEAT SYSTEM

As a result, the nett power input to achieve 40.5 kW of reheating is only $6.8 - 6.24 = 0.56\text{kW}$.



Rotary Energy Recovery Wheels

MECHANICAL SPECIFICATIONS AND FEATURES

cont'd

D. TYPICAL ACCESSORY SECTIONS AND ACCESSORIES cont'd

COOLING ENERGY RECOVERY SECTIONS

I. Rotary Energy Recovery Wheels

To improve Indoor Air Quality (IAQ), it is necessary to introduce and increase the Fresh Air intake quantity. However, by increasing Fresh Air intake, with equal amount of exhaust conditioned air, can increase the building air-conditioning load very significantly, Rotary Energy Recovery wheel can be incorporated to recover otherwise "wasted" cooling energy of the exhaust conditioned air, to pre-cool the Fresh Air. This highly efficient Heat Exchanger wheel can reduce the energy consumption in a Fresh Air AHU by as much as 70% or more.

Alternatively to Rotary Energy Wheel, and when potential cross contamination from exhaust air stream is to be avoided, Air-to-Air Heat Plate type energy Exchanger is also one of the device used to recover cooling energy from exhaust air.

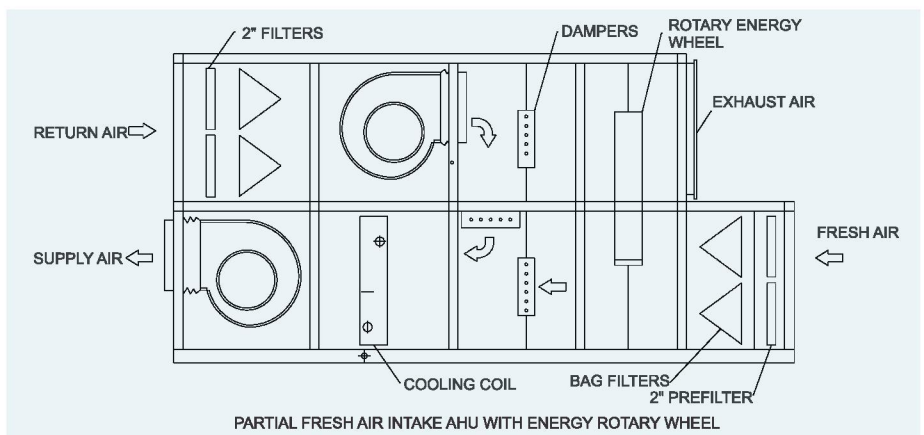
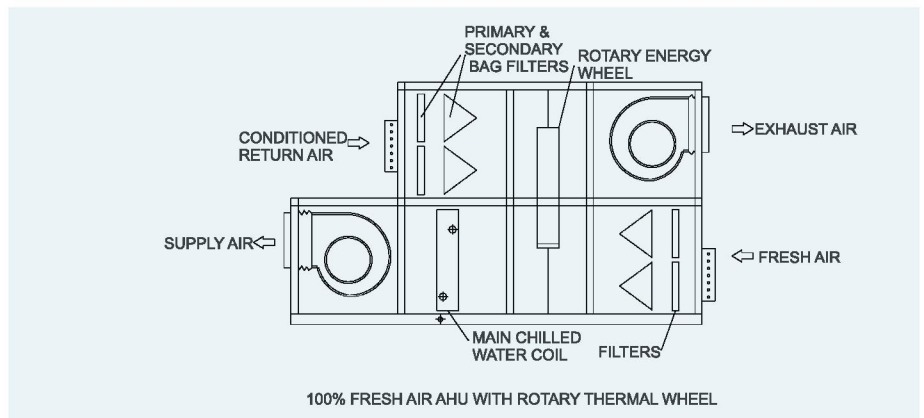

II "Run-Around-Coils" System

The Run-around-coils System consists of 2 nos of drainable water coils interconnected by pipings and with a pump, water is circulated to-and-from the two coils, thus transferring energy from one coil to another.

- a) When one coil is placed in the exhaust Air stream while another is placed in the Fresh Air Stream, cooling energy is recovered from the exhaust air to pre-cool the Fresh Air intake. By using the "Run-Around-Coils" System, there is no potential cross contamination from the exhaust Air Stream to the Fresh Air Stream. The "Run-Around-Coils" System is an effective and economical alternative to Rotary Energy Wheels and Air-to-Air Heat Plate Exchanger.

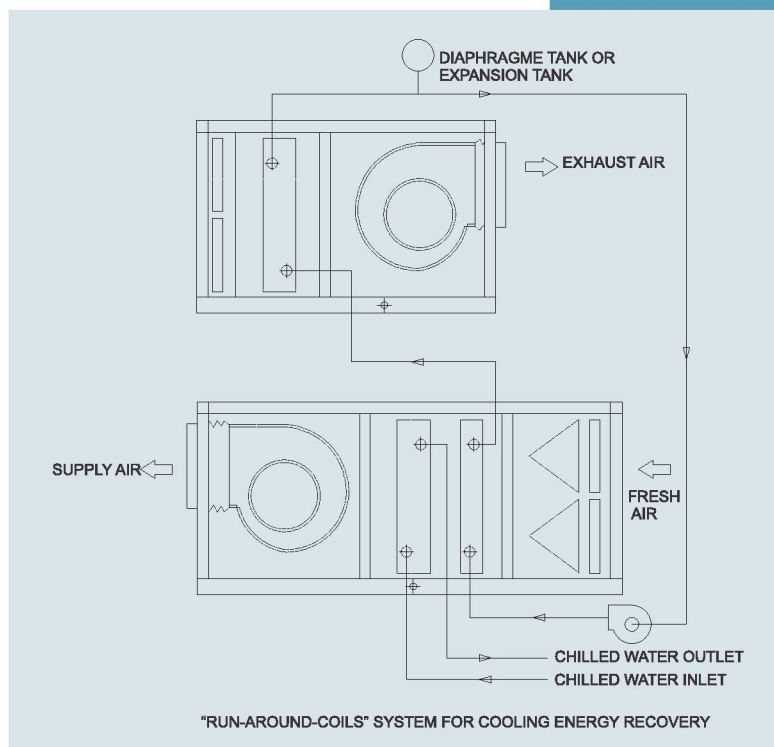

- b) The "Run-Around-Coils" System is also an effective and economical solution to reduce dehumidification load on HVAC application, by providing almost free pre-cooling while providing reheating to lower the humidity of supply air. In this case, one of the Run-Around coil is placed upstream of the Air-Handling unit's cooling coil for pre-cooling while another is placed downstream of the AHU's cooling coil for reheating. This method not only reduces the chiller load by having almost free pre-cooling but also reduce re-heating cost.

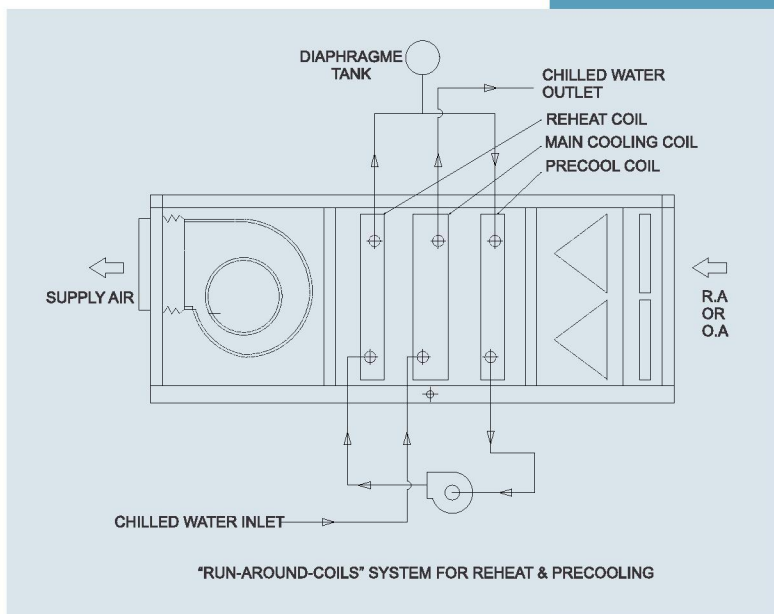

SINGLE ZONE HORIZONTAL UNIT (1" & 2" casing)

FAN, COIL AND FLAT FILTERS COMBINED UNIT

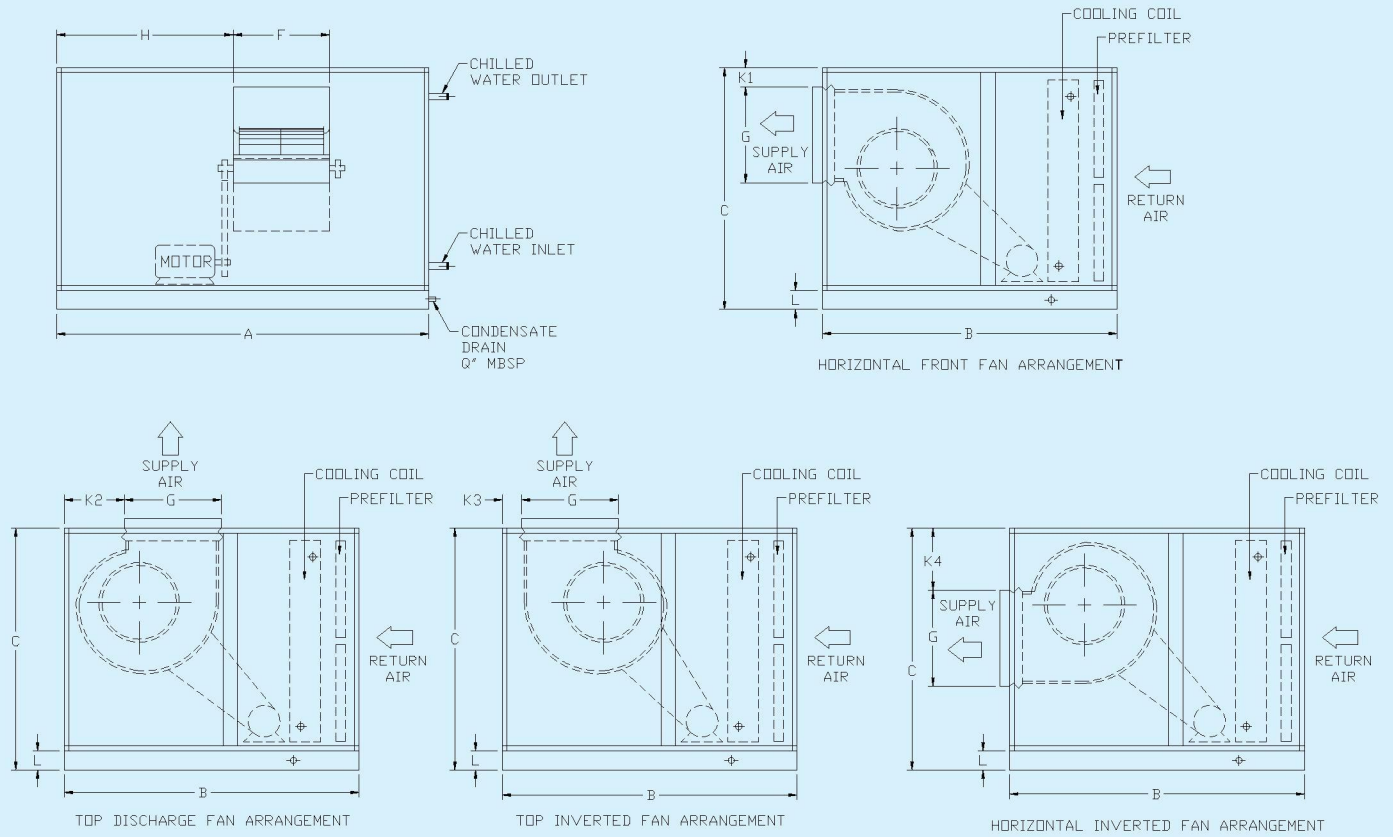

DIMENSIONS - inches

UNIT SIZE	24	34	45	65	82	100	120	160	210	260
A	52	56	64	64	77	77	77	86 1/2	106	126
B	50	55	58	58	61	69	69	74	83	88
C	31 1/2	34 1/2	38 1/2	50 1/2	50 1/2	62	73	81	84 1/2	86 1/2
D	-	-	-	-	-	-	-	-	-	-
E	-	-	-	-	-	-	-	-	-	-
F	12 3/4	14 1/4	16	18	20	25 1/4	25 1/4	28 1/4	32	35 1/2
G	12 3/4	14 1/4	16	18	20	25 1/4	25 1/4	28 1/4	32	35 1/2
H	22	26	29	29	36 1/2	36 1/2	36 1/2	36 1/2	46 3/4	51 1/4
K1	4	4	4	4	4	9 3/4	17	18	16	12
K2	8 3/4	9 1/4	10 1/2	12	13	14 1/2	14 1/2	15 1/2	18 1/4	20 1/4
K3	4	4	4	4	4	4	4	4	3	3
K4	8 3/4	9 1/4	10 1/2	12	13	15 3/4	26	30 1/2	30	28
L	4	4	4	4	4	4	4	4	4	6
Q	1	1	1	1 1/4	1 1/4	1 1/4	1 1/4	1 1/4	1 1/2	2
MAXIMUM MOTOR HP	4.0	5.0	5.5	7.5	15.0	25.0	25.0	25.0	30.0	50.0

NOTES:

- 1) HP is maximum fan motor hp to be installed.
- 2) For size up to 260, fan and coil-filter section are combined as single unit. For size 300, 400 & 500 fan section and coil-filter section are shipped separately for field connection.
- 3) Factory shall issue certified drawing for every unit order prior to fabrication.

SINGLE ZONE HORIZONTAL UNIT

FAN, COIL AND FLAT FILTERS COMBINED UNIT

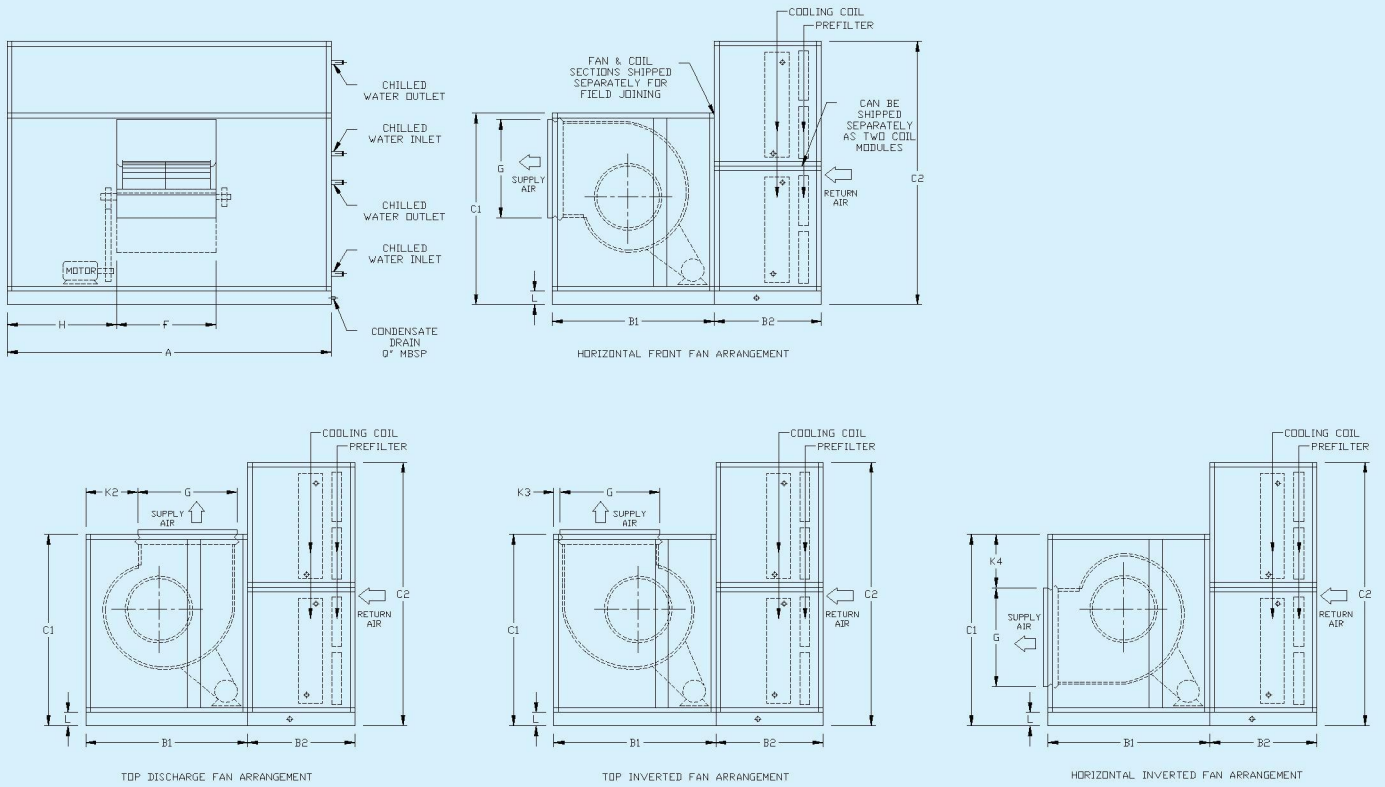

DIMENSIONS - inches

UNIT SIZE	300	400	500
A	126	145	145
B1	64 1/2	72 1/2	80 1/2
B2	48	48	56 1/2
C1	86 1/2	86 1/2	96
C2	102	119	144
F	40	44 1/2	50
G	40	44 1/2	50
H	51 1/4	50 1/4	50 1/4
K1	16 1/2	2 3/4	2 3/4
K2	19 3/4	23 1/4	26 3/4
K3	3	3	3
K4	34 1/2	24 1/4	25 1/4
L	6	6	6
Q	2	2	2
MAXIMUM MOTOR HP	50.0	75.0	75.0



NOTES:

- 1) HP is maximum fan motor hp to be installed.
- 2) For size up to 260, fan and coil-filter section are combined as single unit. For size 300, 400 & 500 fan section and coil-filter section are shipped separately for field connection.
- 3) For size 300, for coil of 8 rows deep, add separate filter rack of 6" to dimension 'B'.
- 4) Factory shall issue certified drawing for every unit order prior to fabrication.

SINGLE ZONE VERTICAL UNIT

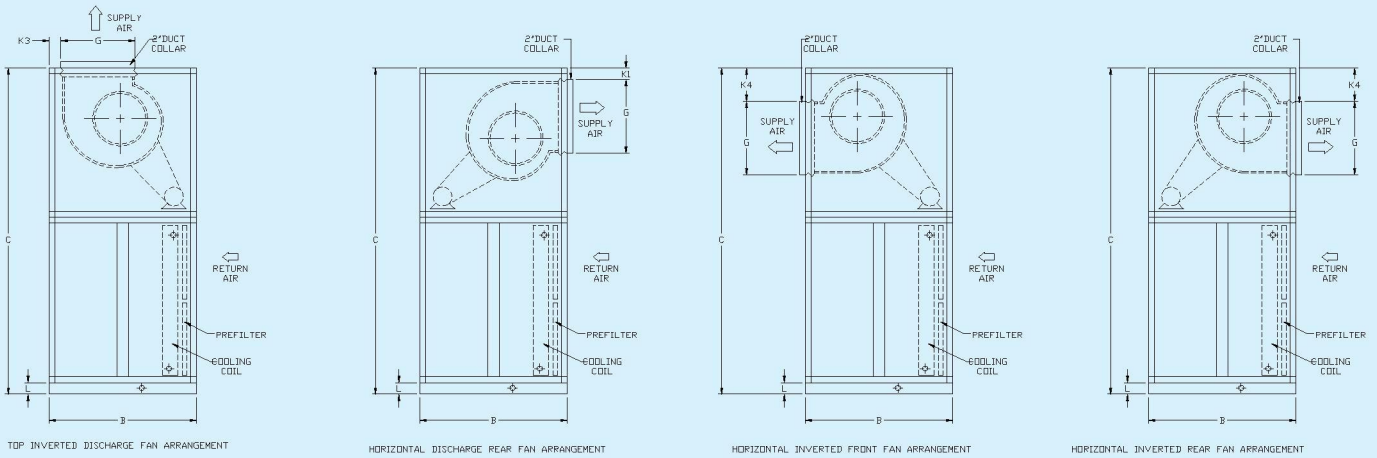
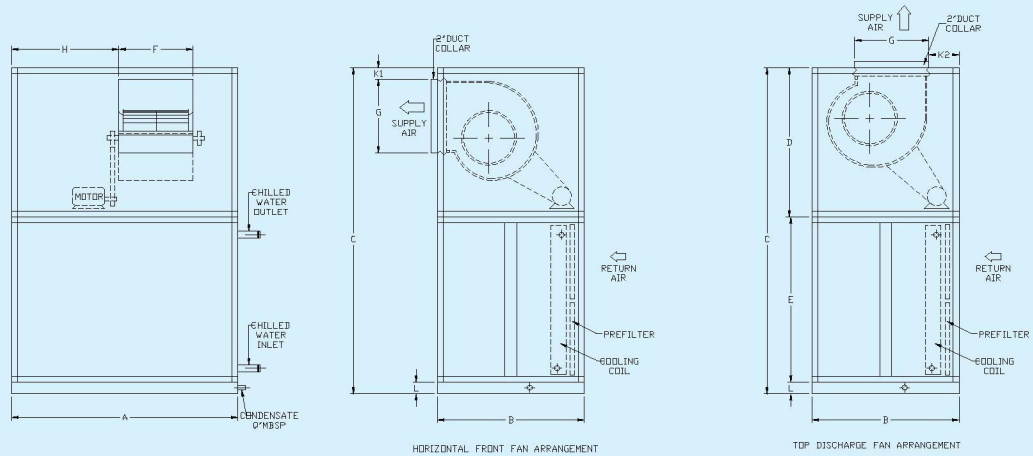

DIMENSIONS - inches

UNIT SIZE	24	34	45	65	82	100	120	160
A	52	56	64	64	77	77	77	86 1/2
B	30 1/2	30 1/2	34 1/2	40	45	50	50	55
C	59	65	73	97	97	112	123	139
D	27 1/2	30 1/2	34 1/2	46 1/2	46 1/2	50	50	58
E	31 1/2	34 1/2	38 1/2	50 1/2	50 1/2	62	73	81
F	12 3/4	14 1/4	16	18	20	25 1/4	25 1/4	28 1/4
G	12 3/4	14 1/4	16	18	20	25 1/4	25 1/4	28 1/4
H	22	26	29	29	36 1/2	36 1/2	36 1/2	36 1/2
K1	4	4	4	4	4	4	4	4
K2	4	4	4	4	4	4	4	4
K3	4	4	4	4	4	4	4	4
K4	8 3/4	9 1/4	10 1/2	12	13	7 3/4	18	11 1/2
L	4	4	4	4	4	4	4	4
Q	1	1	1	1 1/4	1 1/4	1 1/4	1 1/4	1 1/4
MAXIMUM MOTOR HP	4.0	5.0	5.5	7.5	15.0	25.0	25.0	25.0

NOTES:

- 1) HP is maximum fan motor HP to be installed.
- 2) Fan, coil and filter section are combined as single integral unit from size 24 to 82. For size 100 to 160, fan section and coil section are shipped separately for field assembly.
- 3) Drawing indicates fan discharge position in horizontal front arrangement. Horizontal rear, top and top inverted position of fan discharge are available on request. Dimension "K" may vary for other fan discharge position.
- 4) Factory shall issue certified drawing for every unit order prior to fabrication.

MULTIZONE TYPE

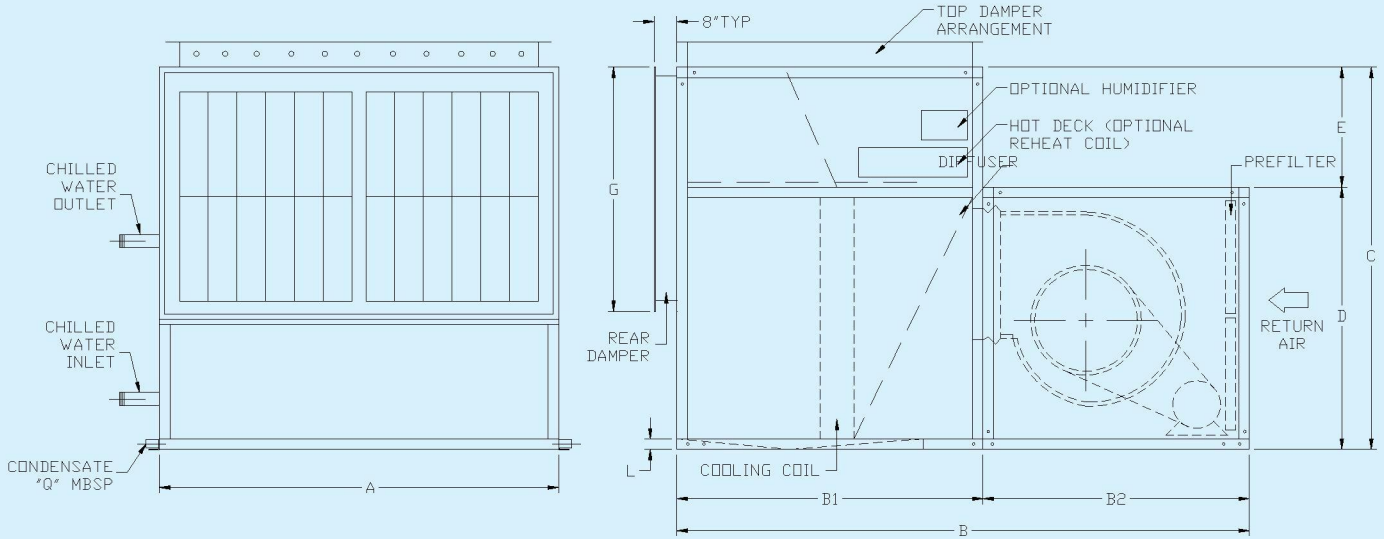

DIMENSIONS - inches

UNIT SIZE	45	65	82	100	120	160	210	260	300	400	500
A	64	64	77	77	77	86 1/2	106	126	126	145	145
B ₁	48	52	52	57	62 1/2	67 1/2	75 1/2	78 1/2	80	91 1/2	104 1/2
B ₂	34 1/2	40	45	50	50	52	56 1/2	61 1/2	64 1/2	72 1/2	80 1/2
B	82 1/2	92	97	107	112 1/2	119 1/2	132	140	144 1/2	164	185
C	56	73	73	84 1/2	100 1/2	108 1/2	116 1/2	118 1/2	142	164 1/2	189 1/2
D	38 1/2	50 1/2	50 1/2	62	73	81	84 1/2	86 1/2	102	119	144
E	17 1/2	22 1/2	22 1/2	22 1/2	27 1/2	27 1/2	32	32	40	45 1/2	45 1/2
G	24	28	32	36	40	48	60	60	72	80	80
L	4	4	4	4	4	4	4	6	6	6	6
Q	1	1 1/4	1 1/4	1 1/4	1 1/4	1 1/4	1 1/2	2	2	2	2
HP	5.5	7.5	15.0	25.0	25.0	25.0	30.0	50.0	50.0	75.0	75.0

NOTES:

- 1) HP is maximum fan motor HP to be installed.
- 2) Hot deck, coil and diffuser are combined as single integral unit for size 43 to 100. Above which hot deck section is separated from coil-diffuser section.
- 3) Zone dampers can be sectionalized depending on number of zones and each zone air flowrates (CFM).
- 4) Factory shall issue certified drawing for every unit order prior to fabrication.

DIMENSIONS FOR ACCESSORY SECTIONS

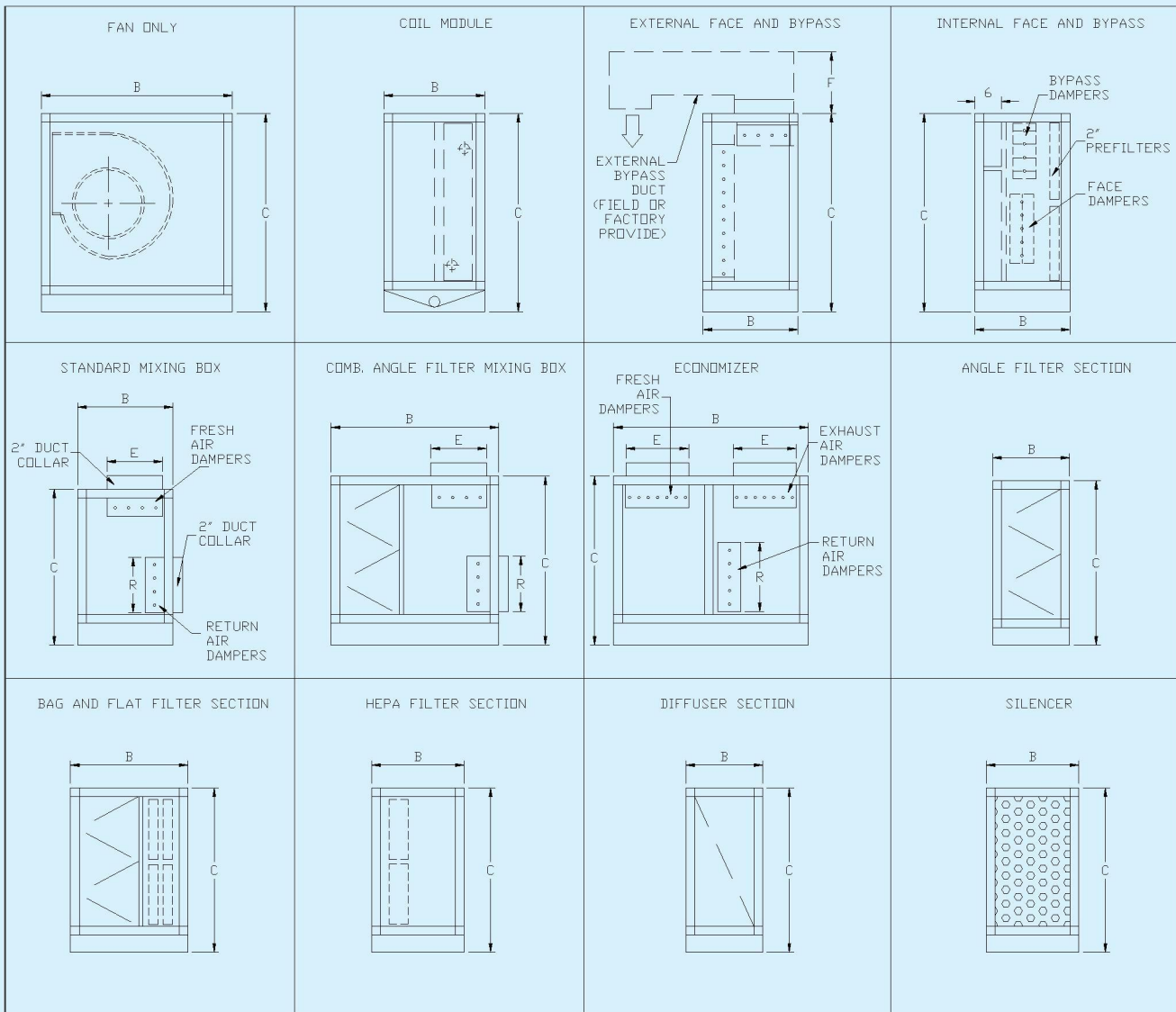

DESCRIPTION		UNIT SIZE													
		24	34	45	65	82	100	120	160	210	260	300	400	500	
Width, In Direction of Air Flow, (not shown)	A	52	56	64	64	77	77	77	86 1/2	106	126	126	145	145	
Height Of Section	C	31 1/2	34 1/2	38 1/2	50 1/2	50 1/2	62	73	81	84 1/2	86 1/2	102	119	144	
Fan Only Section,	B	30 1/2	30 1/2	34 1/2	40	45	50	50	52	56 1/2	61 1/2	64 1/2	72 1/2	80 1/2	
Coil & Flat Filter Section :	Short Sect.	B	25 1/2	30 1/2	30 1/2	27 1/2	27 1/2	27 1/2	27 1/2	32	32	54	54	62 1/2	
	Long Sect.	B	30 1/2	34 1/2	34 1/2	40	40	40	40	46 1/2	46 1/2	70	70	78 1/2	
External Face & By Pass Dampers,	F	8	8	8	10	10	12	12	16	16	20	20	24	24	
		B	17 1/2	17 1/2	17 1/2	22 1/2	22 1/2	22 1/2	22 1/2	29	29	29	29	29	
Internal Face & By Pass, inch	B	22 1/2	22 1/2	22 1/2	22 1/2	22 1/2	22 1/2	22 1/2	22 1/2	24	24	24	24	24	
Mixing Box:	Standard,	B	17 1/2	17 1/2	22 1/2	22 1/2	22 1/2	27 1/2	27 1/2	27 1/2	32	32	43 1/2	43 1/2	48
	Combination,	B	27 1/2	27 1/2	30 1/2	30 1/2	30 1/2	40	40	40	43 1/2	43 1/2	53 1/2	53 1/2	58 1/2
	Economizer,	B	34	34	44	44	44	45	45	45	48 1/2	48 1/2	58 1/2	58 1/2	64 1/2
	Fresh Air Dampers,	E	4.3	4.3	4.3	8.4	8.4	8.4	8.4	8.4	12.2	12.2	16.6	16.6	20.0
	Return Air Dampers,	R	12.2	12.2	12.2	16.6	20.0	24	28	28	32	40	48	48	60
Dampers Width		24	34	44	48	50	50	52	68	80	80	80	100	100	
Angle Filter,	B	22 1/2	22 1/2	22 1/2	22 1/2	22 1/2	22 1/2	22 1/2	22 1/2	24	24	24	24	24	
16" Bag & 2" Flat Filter Section,	B	27 1/2	27 1/2	27 1/2	27 1/2	27 1/2	27 1/2	27 1/2	27 1/2	29	29	29	29	29	
21" Bag & 2" Flat Filter Section,	B	30 1/2	30 1/2	30 1/2	30 1/2	30 1/2	30 1/2	30 1/2	30 1/2	32	32	32	32	32	
HEPA (12") Section,	B	30 1/2	30 1/2	30 1/2	30 1/2	30 1/2	30 1/2	30 1/2	30 1/2	32	32	32	32	32	
Diffuser Section,	B	17 1/2	17 1/2	22 1/2	22 1/2	22 1/2	27 1/2	27 1/2	27 1/2	29	32	32	43 1/2	48	
Silencer Section,	B	46 1/2	46 1/2	46 1/2	46 1/2	46 1/2	46 1/2	46 1/2	46 1/2	48	48	48	48	48	

NOTES:

1) All dimensions are in inches.

2) Reduced fan section height is available for size 300, 400 & 500. To refer to single zone horizontal units dimensions for size 300, 400 & 500.

QUICK COIL SELECTION TABLE

CHILLED WATER & DIRECT EXPANSION COILS

Model Sizes	cfm	Rows	CHILLED WATER					DIRECT EXPANSION	
			80°F DB/ 67°F WB					80°F DB/ 67°F WB	
			No. of Pass	GPM	PD Ft. Wg.	Total Capacity (MBH)	Sensible Capacity (MBH)	Total Capacity (MBH)	Sensible Capacity (MBH)
24	2400	4	4	14.1	1.0	70.7	55.6	73.8	55.2
		6	6	19.7	2.4	98.6	68.9	110.5	72.4
		8	8	23.4	4.0	116.9	77.2	132.7	82.5
34	3400	4	4	20.7	1.4	103.4	79.9	110.7	80.4
		6	6	28.5	3.2	142.6	98.8	161.8	104.7
		8	8	33.6	5.3	167.9	110.4	190.7	117.9
45	4500	4	4	28.8	2.3	143.7	108.3	159.3	112.2
		6	6	39.0	5.2	194.6	133.0	222.6	141.5
		8	8	45.4	8.4	226.9	147.9	255.8	157.5
65	6500	4	4	41.1	2.4	205.2	155.8	225.4	160
		6	6	55.8	5.2	278.9	191.4	318.8	204.4
		8	8	65.3	8.3	326.0	213.3	368.5	227.5
82	8200	4	4	55.1	4.4	275.3	203.0	314.3	212.5
		6	6	73.2	9.5	365.7	247.5	416.8	263.2
		8	8	84.5	14.9	422.1	273.9	464.6	287
100	10000	4	4	68.1	4.5	339.9	249.4	388.5	262.8
		6	6	90.1	9.4	450.1	303.4	513.7	324.3
		8	8	104	14.7	518.2	335.3	572.5	353.4
120	12000	4	4	83.0	3.7	414.7	302.4	474.8	319.8
		6	6	109	8.0	546.6	367.4	625.1	393.4
		8	8	126	12.6	627.3	404.8	695.8	428.1
160	16000	4	4	112	6.0	556.8	404.2	642.5	430.4
		6	6	146	12.7	729.9	489.5	822.0	518.8
		8	8	167	19.9	836.3	540.1	896.8	554.9
210	21380	4	4	154	10.6	770.9	550.6	888.2	581.8
		6	4	189	9.4	942.9	640.4	1080.9	686.1
		8	4	211.0	7.2	1053.9	692.9	1200.6	741.5
260	26000	4	4	197	18.5	981.3	687.5	1100.7	716.7
		6	4	239	15.8	1192.3	797.3	1345.6	843.2
		8	4	265	12.0	1325.5	862.7	1496.6	918.7
300	30000	4	4	226.0	19.3	1129.0	792.7	1265.2	826.6
		6	4	275	16.8	1372.7	919.7	1548.2	972.8
		8	4	306	12.8	1526.8	993.5	1723.2	1060
400	40000	4	4	306	30.0	1529.1	1065.9	1639.7	1075.4
		6	4	372	26.1	1856.8	1236.7	2032.7	1283.7
		8	4	413	19.7	2062.2	1335.9	2279.0	1400.2
500	50000	4	4	385	30.4	1924.1	1337.4	2070.0	1361.6
		6	4	467	26.8	2332.7	1550.0	2559.6	1621.4
		8	4	518	20.2	2587.5	1673.4	2865.0	1766.8

NOTES:

- 1) All coils performance are based on ½" tube coil with nominal airflow and 12FPI for all models.
- 2) Chilled water coils are based on 44°F EWT and 10°F temperature range.
- 3) DX coils are based on R22 @ 40°F SST.

FAN PERFORMANCE DATA (Forward Curve Fan) Quick Selection For Motor Horsepower

Unit Size	Fan Model	Nominal CFM	Total Static Pressure																	
			1.5"			2.0"			2.5"			3.0"			3.5"			4.0"		
			RPM	BHP	RPM	BHP	RPM	BHP	RPM	BHP	RPM	BHP	RPM	BHP	RPM	BHP	RPM	BHP		
24	FDA 250T	2000	1	1462	1.3	1677	1.8													
		2400	1.3	1449	1.6	1620	2	1799	2.4											
		2800	1.7	1463	2.1	1624	2.5	1771	2.8											
34	FDA 280T	2800	1.4	1256	1.8	1450	2.3	1629	2.8											
		3400	1.9	1265	2.3	1400	2.7	1540	3.2											
		4000	2.5	1299	3	1423	3.4	1744	3.9											
45	FDA 315T	3800	2	1145	2.6	1296	3.2	1437	3.9											
		4500	2.6	1142	3.2	1276	3.9	1406	4.6											
		5200	3.4	1162	4.1	1281	4.7	1395	5.4											
65	FDA 355T	5600	2.9	974	3.4	1087	4.1	1208	5											
		6500	3.8	996	4.4	1094	5.1	1188	5.8											
		7300	4.7	1022	5.5	1115	6.2	1203	7											
82	FDA 400T	7200	3.7	889	4.4	1112	6.1	1200	6.9											
		8200	4.7	910	5.5	997	6.4	1079	7.3											
		9200	6	938	6.9	1019	7.8	1096	8.7											
100	FDA 500T	9000	4	731	5.1	817	6.2	901	7.5											
		10000	4.7	736	5.8	817	7	894	8.3											
		11000	5.5	743	6.7	822	7.9	896	9.3											
120	FDA 500T	10000	4.7	736	5.8	817	7	894	8.3											
		12000	6.4	752	7.6	829	9	900	10.4											
		14000	8.6	776	10	846	11.5	915	13											
160	FDA 560T	13000	5.9	646	7.3	716	8.7	786	10.3											
		16000	8.6	667	11.5	732	11.8	792	13.4											
		19000	12.1	697	14.5	756	15.7	812	17.6											
210	FDA 630T	18000	9.2	592	11.1	653	13.1	709	15.3											
		21000	12.9	609	14.5	666	16.5	721	18.9											
		24000		645	19.4	686	21.2	734	23.4											
260	FDA 710T	23000	11.6	522	13.7	575	16	625	18.5											
		26000	14.8	537	17.1	585	19.6	632	22.1											
		30000		559	22.8	605	25.5	648	28.2											
300	FDA 800X	25000	11.5	445	14.5	493	17.2	540	20.4											
		30000	15.5	452	19	498	22.2	545	25.8											
		35000		458	24.4	507	28.5	548	32.1											

NOTES:

- 1) For operation in shaded area, to consult factory for alternative fan selection.
- 2) Above data is useful for guide estimate of motor size required.
- 3) Actual Fan RPM and BHP shall be computer selected once final total static pressure and air flow rates are determined.

FAN PERFORMANCE DATA (Backward Air Foil Blower) Quick Selection For Motor Horsepower

Unit Size	Fan Model	Nominal CFM	Total Static Pressure																	
			2.5"			3.0"			3.5"			4.0"			5.0"			6.0"		
			RPM	BHP	RPM	BHP	RPM	BHP	RPM	BHP	RPM	BHP	RPM	BHP	RPM	BHP	RPM	BHP		
45	ADA 315T	4000	2488	2.6	2607	2.9	2720	3.3	2827	3.7	3029	4.4	3218	5.2	3350	6	3491	6.9		
		4500	2648	3.1	2762	3.5	2871	3.9	2975	4.3	3168	5.1	3350	6	3491	6.9	3632	7.8		
		5000	2816	3.7	2924	4.2	3028	4.6	3128	5.1	3316	6	3491	6.9	3632	7.8	3874	8.7		
65	ADA 355T	5600	2294	3.8	2397	4.2	2493	4.7	2585	5.2	2757	6.2	2918	7.3	3093	8.9	3258	10.5		
		6500	2504	5	2596	5.5	2687	6.1	2774	6.6	2940	7.7	3093	8.9	3258	10.5	3495	12.4		
		7300	2703	6.3	2786	6.9	2869	7.5	2951	8.1	3109	9.3	3258	10.5	3495	12.4	3737	14.3		
82	ADA 400T	7200	2109	4.8	2195	5.4	2278	6.1	2359	6.7	2510	8	2651	9.3	2796	11.1	2937	12.6		
		8200	2282	6.1	2363	6.8	2441	7.5	2516	8.2	2660	9.6	2796	11.1	2937	12.6	3178	14.5		
		9200	2461	7.8	2538	8.5	2612	9.2	2683	9.9	2818	11.5	2947	13.1	3086	14.9	3228	16.3		
100	ADA 500T	9000	1452	5	1528	5.8	1600	6.6	1670	7.4	1803	9.1	1933	11	2063	12.8	2193	14.5		
		10000	1525	5.9	1601	6.8	1671	7.6	1737	8.5	1863	10.3	1983	12.2	2110	14.9	2240	16.6		
		12000	1673	8.1	1746	9.1	1816	10	1881	11	2000	13.1	2110	14.9	2240	16.6	2370	18.7		
120	ADA 500T	10000	1525	5.9	1601	6.8	1671	7.6	1737	8.5	1863	10.3	1983	12.2	2110	14.9	2240	16.6		
		12000	1673	8.1	1746	9.1	1816	10	1881	11	2000	13.1	2110	14.9	2240	16.6	2370	18.7		
		14000	1839	10.9	1901	12	1964	13.1	2027	14.2	2146	16.5	2253	18.8	2360	21.1	2467	23.4		
160	ADA 560T	13000	1387	7.8	1451	8.9	1513	10	1572	11.1	1684	13.4	1789	15.8	1894	18.3	1999	21.2		
		16000	1560	11.2	1619	12.5	1675	13.8	1729	15.1	1832	17.8	1929	20.6	2026	23.1	2129	25.9		
		19000	1746	16	1799	17.3	1850	18.7	1900	20.2	1995	23.3	2086	26.4	2181	29.1	2272	33.2		
210	ADA 630T	18000	1293	11.4	1352	12.8	1409	14.2	1463	15.8	1564	19	1656	22.2	1756	27.1	1857	32		
		21000	1414	15.2	1466	16.8	1518	18.4	1569	20	1666	23.5	1756	27.1	1857	32	1954	36.9		
		24000	1546	20	1592	21.8	1637	23.6	1683	25.4	1773	29.1	1860	32.9	1954	36.9	2051	43.8		
260	ADA 710T	24000	1209	15.8	1257	17.8	1302	19.9	1346	21.9	1427	26	1504	30.1	1581	37.4	1658	44.9		
		28000	1332	21.4	1376	23.4	1419	25.6	1460	27.9	1537	32.6	1609	37.4	1686	45.8	1763	52.7		
		32000	1460	28.6	1501	30.8	1540	33	1579	35.3	1652	40.4	1721	45.8	1798	52.7	1875	60.6		
300	ADA 800X	27000	998	16.6	1041	18.6	1082	20.8	1122	23	1196	27.7	1268	32.5	1340	39.4	1412	47.3		
		32000	1101	22.7	1142	25.1	1181	27.5	1219	30	1288	35.1	1354	40.4	1429	47.3	1506	55.2		
		37000	1208	30.3	1247	33.2	1285	36	1320	38.8	1387	44.4	1449	50.1	1516	57.1	1583	64		
400	ADA 900X	36000	934	24.1	969	26.7	1003	29.4	1035	32.2	1098	38	1159	44	1219	50.1	1279	57.1		
		42000	1030	32.6	1064	35.8	1096	38.9	1126	42	1183	48.2	1238	54.8	1298	62.7	1358	70.6		
		50000	1159	46.8	1192	50.8	1224	54.7	1253	58.5	1307	65.9	1357	73.2	1417	80.1	1477	87.6		
500	ADA 1000X	40000	775	23.5	811	26.7	844	29.9	876	33.3	938	40.3	997	47.6	1057	57.1	1117	64.6		
		50000	881	35.4	914	39.2	945	42.9	975	46.7	1031	54.6	1083	62.9	1143	72.1	1195	80.1		
		60000	991	50.9	1022	55.6	1051	60.2	1079	64.8	1132	73.8	1181	82.9	1243	90.1	1295	97.6		

NOTES:

- 1) For operation in shaded area, to consult factory for alternative fan selection.
- 2) Above data is useful for guide estimate of motor size required.
- 3) Actual Fan RPM and BHP shall be computer selected once final total static pressure and air flow rates are determined.

FAN PERFORMANCE DATA (Backward Flat Blade Blower BF) Quick Selection For Motor Horsepower

Unit Size	Fan Model	Nominal CFM	Total Static Pressure																	
			2.5"			3.0"			3.5"			4.0"			5.0"			6.0"		
			RPM	BHP	RPM	BHP	RPM	BHP	RPM	BHP	RPM	BHP	RPM	BHP	RPM	BHP	RPM	BHP		
45	BDB 315T	4000	2.6	2609	3	2721	3.3	2829	3.7	3037	4.5	3235	5.3							
		4500	3.2	2772	3.6	2876	4	2976	4.4	3171	5.3	3357	6.1							
		5000	3.8	2944	4.3	3041	4.7	3136	5.2	3318	6.1	3493	7							
65	BDB 355T	5600	4	2409	4.4	2504	4.9	2593	5.4	2759	6.4	2914	7.5							
		6500	5.3	2611	5.8	2702	6.3	2789	6.9	2951	8	3099	9.2							
		7300	6.6	2802	7.3	2886	7.9	2968	8.5	3125	9.7	3272	10.9							
82	BDB 400T	7200	5.2	2209	5.8	2294	6.4	2374	7	2521	8.3	2659	9.6							
		8200	6.6	2371	7.3	2453	8	2532	8.7	2678	10.1	2810	11.5							
		9200	8.4	2543	9.2	2619	9.9	2693	10.7	2836	12.2	2968	13.7							
100	BDB 500T	9000	5.3	1539	6.2	1612	7	1681	7.9	1813	9.6	1937	11.5							
		10000	6.3	1611	7.2	1682	8.1	1749	9	1876	10.9	1994	12.9							
		12000	8.6	1764	9.6	1830	10.6	1894	11.7	2013	13.9	2125	16.1							
120	BDB 500T	10000	6.3	1611	7.2	1682	8.1	1749	9	1876	10.9	1994	12.9							
		12000	8.6	1764	9.6	1830	10.6	1894	11.7	2013	13.9	2125	16.1							
		14000	11.7	1928	12.7	1989	13.9	2048	15	2161	17.5	2267	20							
160	BDB 560T	13000	8.2	1466	9.3	1526	10.4	1584	11.5	1692	13.9	1795	16.4							
		16000	11.8	1634	13.2	1692	14.6	1748	16	1850	18.6	1944	21.4							
		19000	16.9	1812	18.2	1865	19.7	1917	21.3	2016	24.6	2107	27.8							
210	BDB 630T	18000	11.8	1357	13.5	1412	15.1	1464	16.7	1562	19.9	1654	23.2							
		21000	15.6	1473	17.3	1525	19.2	1575	21.1	1669	24.8	1756	28.6							
		24000	20.6	1597	22.3	1644	24.2	1691	26.2	1780	30.5	1865	34.8							
260	BDB 710T	24000	16.9	1251	18.8	1298	20.8	1342	22.8	1427	26.9	1505	31.2							
		28000	22.9	1367	25	1411	27.2	1452	29.5	1532	34	1607	38.8							
		32000	30.5	1490	32.9	1530	35.3	1569	37.8	1644	42.8	1715	48							
300	BDB 800X	27000	16.8	1053	19.1	1094	21.4	1135	23.8	1211	28.6	1284	33.5							
		32000	22.8	1156	25.3	1195	27.9	1232	30.6	1303	36.1	1370	41.7							
		37000	31	1266	33.5	1302	36.2	1336	39	1402	45.1	1465	51.4							
400	BDB 9800X	36000	23.7	956	26.4	994	29.2	1029	32.1	1095	38.4	1157	44.7							
		42000	32.2	1039	35.2	1075	38.3	1110	41.3	1174	47.9	1233	55							
		50000	46.5	1160	50.3	1191	54	1222	57.6	1282	64.8	1340	72.3							
500	BDB 1000X	40000	23.8	820	27.2	854	30.6	887	34	950	41.1	1009	48.3							
		50000	35.3	925	39.1	956	43.2	986	47.3	1042	55.8	1096	64.3							
		60000	52.0	1038	56.0	1066	60.2	1093	64.7	1145	74.2	1194	84.2							

NOTES:

- 1) For operation in shaded area, to consult factory for alternative fan selection.
- 2) Above data is useful for guide estimate of motor size required.
- 3) Actual Fan RPM and BHP shall be computer selected once final total static pressure and air flow rates are determined.

ESTIMATED UNIT WEIGHTS (LBS)

MODEL SIZE	24	34	45	65	82	100	120	160	210	260	300	400	500
------------	----	----	----	----	----	-----	-----	-----	-----	-----	-----	-----	-----

SINGLE ZONE (FAN & COIL) WITH FORWARD CURVE BLOWER

SINGLE	HORIZONTAL	520	615	800	920	1260	1500	1680	2100	2600	3100	3450	NA	NA
SKIN 1"	VERTICAL	545	650	870	1020	1400	1800	2100	2650	NA	NA	NA	NA	NA
DOUBLE	HORIZONTAL	580	680	860	1020	1420	1610	1800	2220	2850	3450	3850	NA	NA
WALL 1"	VERTICAL	620	730	930	1150	1600	1920	2360	2850	NA	NA	NA	NA	NA

SINGLE ZONE (FAN & COIL) WITH AF/BF FAN

SINGLE	HORIZONTAL	570	660	850	970	1400	1660	1880	2330	2850	3300	3650	4600	5800
SKIN 1"	VERTICAL	595	695	920	1070	1540	1960	2300	2880	NA	NA	NA	NA	NA
DOUBLE	HORIZONTAL	630	725	910	1070	1560	1770	2000	2450	3100	NA	NA	5000	6300
WALL 1"	VERTICAL	670	775	980	1200	1740	2080	2560	3080	NA	NA	NA	NA	NA

ACCESSORY SECTIONS

FAN SECTION	1" SINGLE FC	360	410	510	580	860	1200	1320	1700	2100	2600	2900	NA	NA
	1" DOUBLE FC	380	440	540	640	940	1380	1550	2050	2350	2800	3100	NA	NA
	1" SINGLE AF/BF	NA	NA	560	630	1020	1310	1440	1930	2350	2800	3100	3800	4600
	1" DOUBLE AF/BF	NA	NA	590	690	1100	1490	1670	2280	2600	3000	3300	4200	5100
MULTI ZONE	1" SINGLE (NO COIL)	NA	NA	520	800	900	1030	1160	1500	1800	2400	2800	3900	4700
	1" DOUBLE (NO COIL)	NA	NA	590	900	1060	1300	1550	1950	2250	2880	3300	4000	4900

DIFFUSER D.W. SECTION	120	160	195	225	290	370	430	580	780	1000	1180	1260	1550	
LONG COIL SECTION (NO COIL)	200	270	310	360	440	500	540	720	900	1100	1250	1400	1700	
SHORT COIL SECTION (NO COIL)	160	200	250	300	360	390	460	620	820	950	1050	1160	1400	
EXT F & BYPASS (NO DUCT)	100	110	120	135	170	200	230	290	380	480	590	700	860	
INT F & BYPASS	70	80	90	105	135	160	195	250	315	400	500	600	750	
FLAT & BAG FILTERS SECTION WITH FILTERS	230	260	310	360	460	530	600	710	900	1050	1200	1350	1650	
HEPA SECTION WITH FILTERS	320	350	440	540	700	800	910	1150	1450	1650	1850	2200	2700	
ANGLE FILTER SECT. W. FILTERS	150	170	200	230	280	320	360	410	520	570	660	780	980	
COMB MIX & FILTER SECTION C/W FILTERS	170	240	300	350	460	530	600	740	900	1100	1300	1550	2000	
MIXING BOX	120	160	200	230	300	380	440	600	800	1050	1230	1550	1950	
ECONOMIZER SECTION	220	300	360	420	520	700	800	1080	1400	1800	2100	2600	3200	
SILENCER SECTION	350	430	560	680	790	900	1100	1300	1650	1950	2300	2800	3500	
1/2" O.D. DW COILS @ 12 FPI	3 ROWS	95	135	160	205	240	270	320	370	460	550	600	750	920
	4 ROWS	110	155	193	240	285	320	390	450	570	680	760	940	1180
	5 ROWS	125	185	210	285	325	375	470	540	670	820	920	1160	1440
	6 ROWS	140	205	230	310	370	435	520	620	780	950	1070	1350	1690
	8 ROWS	160	260	270	380	460	540	650	780	990	1220	1380	1750	2200

NOTES:

- 1) Single zone (fan & coils) section excludes weight of coil, but includes largest size motor and drive package;
- 2) Multi-zone section excludes weight of coil, heating coil, humidifier, fan section, filter section, etc. Zone dampers included;
- 3) Fan section includes weight of largest motor and drive package
- 4) All accessory sections are of double wall 1" construction. For single skin accessory sections, assume weight to be 0.93 of double wall sections.
- 5) For 2" double-wall casing, with polyurethane insulation, multiply above weights for casing parts by 1.3 to obtain estimate weight.



Specifications in this catalogue are subject to change without notice in order that SMARTECH may bring the latest innovations to their customer.