

**The Quality Industrial Fans of Germany**

**Housing & Framing**  
Rugged heavy gauge all welded steel housing with substantial framing sections for maximum rigidity.

**Laminar Wheel**  
Superior combination of high efficiency, stable operation and low noise level.

**Bearings**  
Heavy duty precision ball or roller bearings sized for generous B-10 life.

**Shafts**  
Turned ground and polished or fully machined to close dimensional tolerance.

**Heavy Duty Structural Bearing Pedestal**

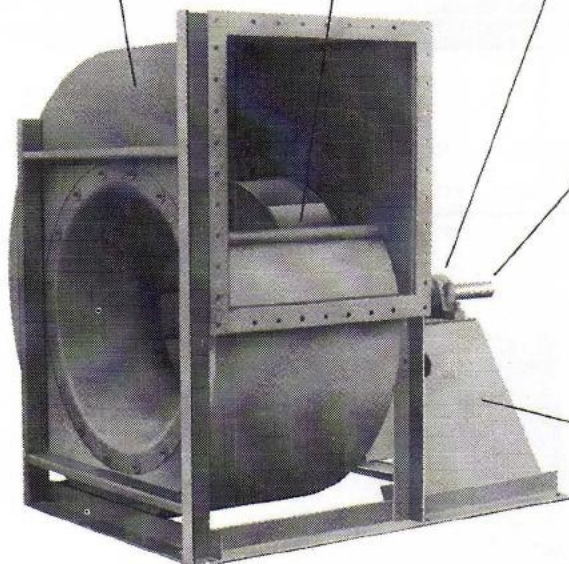

**Classes of Construction**

Arrg't	Fan Size Range	
	Class I & II	Class III
A/1 - SISW	1350 - 8075	2225 - 6600
A/3 - SISW	1825 - 8075	2225 - 6600
A/9 - SISW	1350 - 6000	2225 - 8000
A/10 - SISW	1350 - 3650	N.A.
A/3 - DIDW	1825 - 8075	2225 - 6600

**Shafts and Bearings**

**Shafts**

Selected to have suitable strength and operate well below the first critical speed for each maximum class condition.

**Bearings**

Antifriction, grease lubricated, self aligning ball or roller types, solid or split housing, manufactured to internationally adopted standards by companies having worldwide acceptance and support services. Bearings are selected for continuous belt driven operation with a generous bearing life throughout each full class range.

**Capacities**

500 CFM to 280,000 CFM

**Pressures**

Class I to 9" S.P. (Size 1350 - 3650)  
 Class I to 8" S.P. (Size 4025 - 8075)  
 Class II to 13" S.P. (Size 1350 - 8075)  
 Class III to 21" S.P. (Size 2225 - 6600)

**Temperatures**

Operating Temperatures to 800° F  
 See Table 2, Page 6

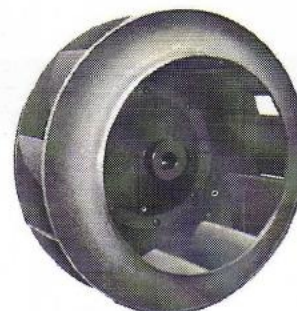
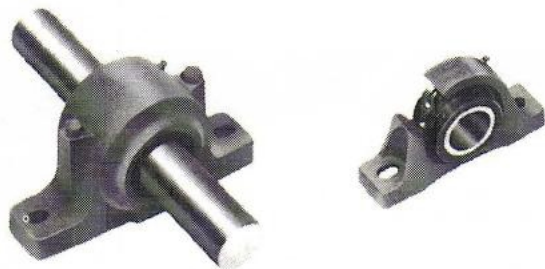

# Dimensional Data

## S.I.S.W. Arrangements 1, 3, 4, 9

DIMENSIONS: mm

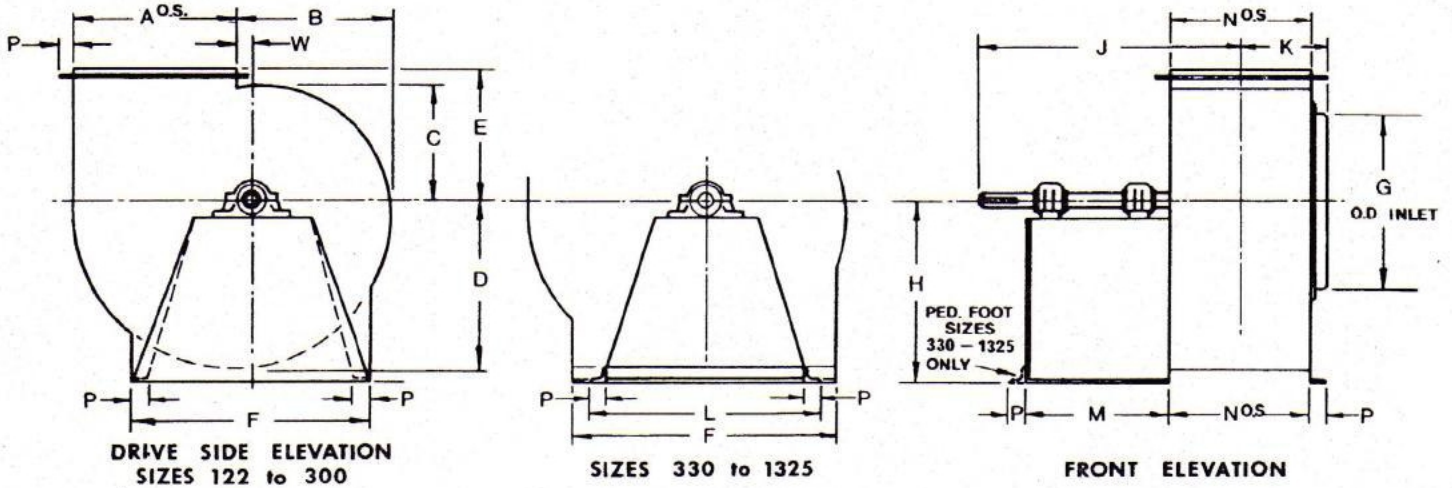

Note: Fig. numbers in following tables refer to Discharge Positions diagrams.

FAN SIZE	SHAFT DIA INS		A	B	C	D	E (FIGURE No.)			F	G
	CL1	CL2					1 - 5 11 - 15	6 & 16	7 & 8 17 & 18		
122	1	1	308	258	214	310	263	263	330	432	346
135	1	1.1/4	340	286	237	342	285	285	356	473	384
150	1.1/4	1.1/4	375	315	261	380	305	305	381	527	425
165	1.1/4	1.1/2	409	347	286	416	330	330	406	578	476
182	1.1/2	1.1/2	456	383	316	462	374	374	438	638	518
200	1.1/2	2	498	422	349	506	394	394	470	698	564
222	2	2.1/4	554	470	389	563	432	432	533	775	622
245	2	2.1/4	610	512	426	619	470	470	572	854	686
270	2.1/4	2.1/4	671	568	469	682	514	514	616	943	762
300	2.1/4	2.1/4	745	631	522	757	565	565	667	1044	835
330	2.1/4	2.1/4	822	694	573	834	630	630	711	1153	921

FAN SIZE	H (FIGURE No.)						J		K		L	M	N	P	W
	1 & 11 2 & 12	3 & 13	4 & 14	5 & 15	6 & 16	7 & 17 8 & 18	Arr 1, 9	Arr 3	Arr 1, 9	Arr 3					
122	371	337	311	286	273	254	500	290	175	215	N/A	273	276	38	22
135	403	368	343	311	298	279	515	320	190	230	N/A	273	303	38	25
150	445	406	375	343	324	305	565	350	210	250	N/A	292	337	38	30
165	483	445	500	375	356	330	595	380	235	275	N/A	292	371	38	34
182	530	489	451	413	387	362	645	410	240	280	N/A	311	408	38	36
200	575	533	492	448	422	394	665	430	260	300	N/A	311	446	38	41
222	650	603	559	508	470	432	800	455	300	330	N/A	419	497	51	46
245	711	660	610	559	514	470	860	480	325	350	N/A	457	546	51	49
270	778	720	667	610	565	514	940	530	350	400	N/A	508	602	51	56
300	860	797	737	670	619	565	1035	565	385	440	N/A	565	669	51	62
330	940	873	806	737	679	622	1130	600	420	470	864	635	736	51	67

NOTE: INCH SIZES USED FOR SHAFTS WHILE STILL AVAILABLE

DISCHARGE POSITIONS. CLOCKWISE ROTATION SHOWN (viewed from drive side), ANTI-CLOCKWISE — OPPOSITE HAND

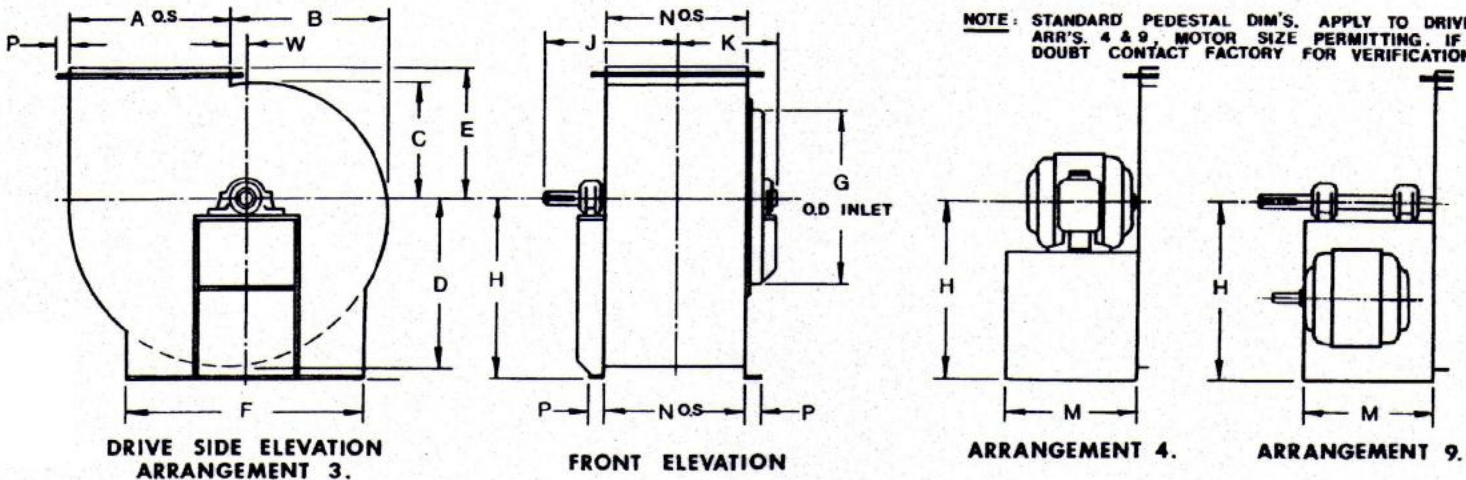
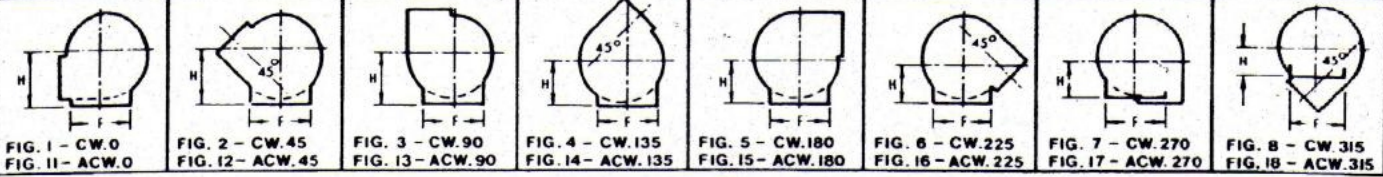

FAN SIZE	SHAFT DIA. INS.		A	B	C	D	E (FIGURE No.)			F	G
	CL1	CL2					1-5 11-15	6 & 16	7 & 8 17 & 18		
365	2½	2½	905	771	637	922	700	895	711	1270	1032
402	2½	3	1000	848	702	1016	768	984	781	1400	1123
445	3	3	1105	937	774	1123	838	1073	851	1524	1244
490	3	3½	1216	1035	857	1246	921	1181	933	1702	1365
542	3	3½	1346	1142	944	1368	1016	1305	1029	1886	1511
600	3½	4	1486	1263	1043	1513	1124	1444	1137	2083	1680
660	3½	4½	1635	1382	1140	1663	1226	1575	1238	2292	1833
730	4	5	1806	1535	1269	1840	1346	1730	1359	2534	2027
807	4½	5½	1997	1697	1403	2035	1505	1927	1518	2800	2242
890	5	6	2200	1886	1545	2242	1651	2115	1664	3086	2467

FAN SIZE	H (FIGURE No.)						J		K		L	M	N	P	W
	1 & 11 2 & 12	3 & 13	4 & 14	5 & 15	6 & 16	7 & 17 8 & 18	ARR 1,9	ARR 3	ARR 1,9	ARR 3					
365	1032	959	883	806	756	699	1170	635	460	510	864	635	812	51	76
402	1133	1054	972	889	829	768	1285	740	525	615	1016	711	895	51	82
445	1273	1175	1080	991	914	838	1400	815	570	660	1168	749	988	76	92
490	1394	1289	1187	1083	1003	921	1500	865	620	710	1168	800	1089	76	102
542	1534	1422	1308	1194	1105	1016	1620	950	680	770	1219	838	1204	76	111
600	1689	1565	1441	1314	1207	1124	1790	1015	745	835	1372	940	1332	76	125
660	1851	1715	1575	1441	1327	1226	1895	1080	810	900	1524	978	1464	76	138
730	2038	1892	1740	1588	1467	1346	2010	1155	890	980	1676	1016	1620	76	154
807	2286	2120	1905	1778	1625	1403	2425	1295	1000	1120	1905	1346	1794	102	171
890	2508	2337	2108	1968	1765	1550	2680	1410	1090	1210	2160	1485	1976	102	189



## STANDARD DESIGNATIONS

### ARRANGEMENTS OF DRIVE

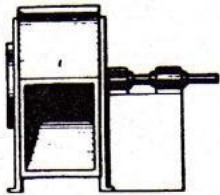

**Arrangement No. 1, SW, S1**  
For belt drive or direct connection. Wheel overhung. Two bearings on base.

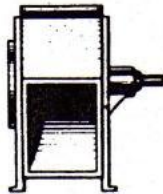

**Arrangement No. 2, SW, S1**  
For belt drive or direct connection. Wheel overhung. Bearings in bracket supported by fan housing.



**Arrangement No. 3, SW, S1**  
For belt drive or direct connection. One bearing on each side and supported by fan housing. Not recommended in sizes 740 diameter wheel and smaller.

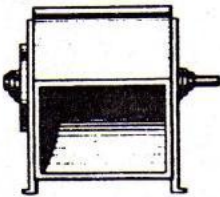

**Arrangement No. 3, DW, DI**  
For belt drive or direct connection. One bearing on each side and supported by fan housing.

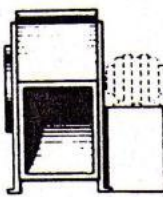

**Arrangement No. 4, SW, S1**  
For direct drive. Wheel overhung on prime mover shaft. No bearings on fan. Base or equivalent for prime mover.

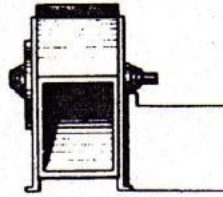

**Arrangement No. 7, SW, S1**  
For belt drive or direct connection. Arrangement No. 3 plus base for prime mover. Not recommended in sizes 740 diameter and smaller.

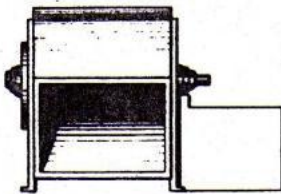

**Arrangement No. 7, DW, DI**  
For belt drive or direct connection. Arrangement No. 3 plus base for prime mover.

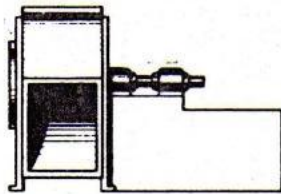

**Arrangement No. 8, SW, S1**  
For belt drive or direct connection. Arrangement No. 1 plus base for prime mover.

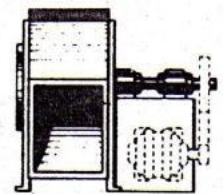

**Arrangement No. 9, SW, S1**  
For belt drive. Arrangement No. 1 designed for mounting prime mover on side of base.

### MOTOR POSITION, BELT OR CHAIN DRIVE

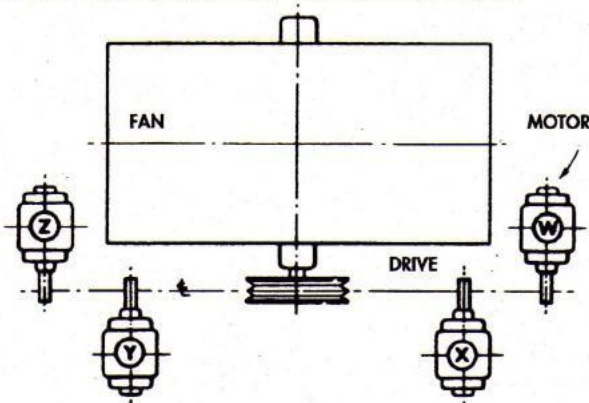

Location of motor is determined by facing the drive side of fan and designating the motor position by letters W, X, Y or Z as the case may be.

### DESIGNATION OF DIRECTION OF ROTATION AND DISCHARGE

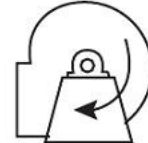

**CW.0**  
FIG-1



**ACW.0**  
FIG-11

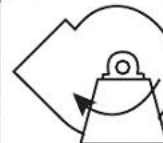

**CW.45**  
FIG-2



**ACW.45**  
FIG-12



**CW.90**  
FIG-3



**ACW.90**  
FIG-13



**CW.135**  
FIG-4



**ACW.135**  
FIG-14



**CW.180**  
FIG-5



**ACW.180**  
FIG-15



**CW.225**  
FIG-6



**ACW.225**  
FIG-16



**CW.270**  
FIG-7



**ACW.270**  
FIG-17

Direction of Rotation is determined from drive side for either single or double width, or single or double inlet fans. (The driving side of a single inlet fan is considered to be the side opposite the inlet regardless of actual location of the drive.) For fan inverted for ceiling suspension, Direction of Rotation and Discharge is determined when fan is resting on floor.