

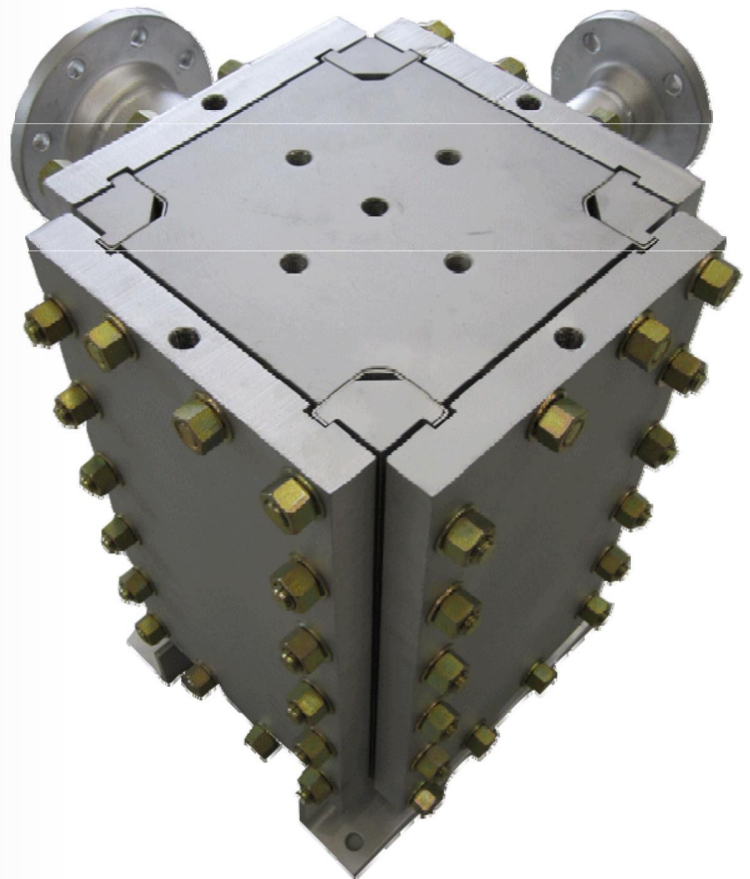

WeldPack[®]
Welded Plate
Heat Exchanger



WeldPack® Welded Plate Heat Exchanger

Vitherm WeldPack® welded plate heat exchanger is a compact solution to work in high operating pressures, and high or low operating temperatures.

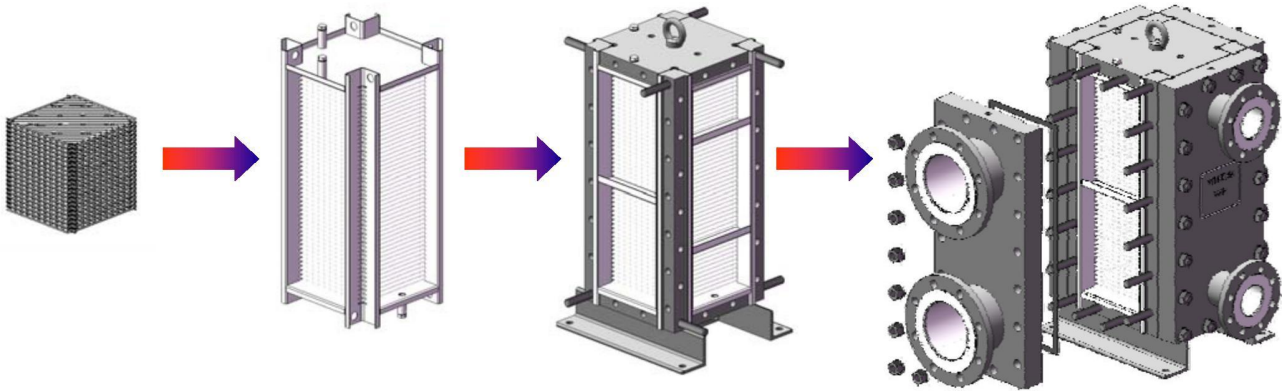

Advantages of WeldPack® :

- no interplate gaskets
- accessible on both sides
- easier to access & easier to clean
- closer temperature approach possible
- compactness – very little space required
- lower capital cost
- low-maintenance
- fully welded by robot

APPLICATIONS :

- liquid - liquid
- condenser with or without sub-cooling
- condenser with or without inert
- reboiler
- steam heater

INDUSTRY SECTORS :

- Oil & Gas Industry
- Vegetable Oil Industry
- Chemical/Petrochemical Industry
- Pharmaceutical Industry

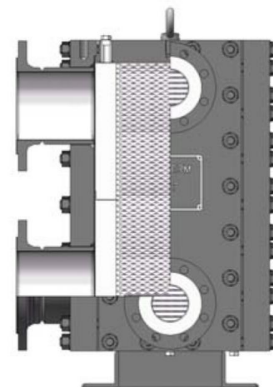

Vertical Unit

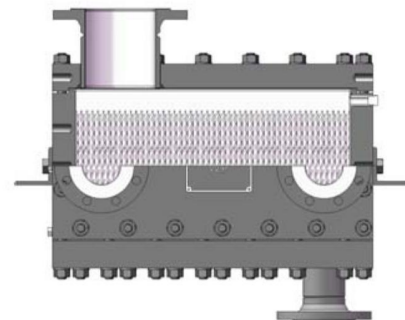

Horizontal Unit

WeldPack® Welded Plate Heat Exchanger

Available Materials:

Any alloy that can be pressed & welded

- SS316L (Standard)
- Titanium & Titanium + 0.2 Pd.
- Hastelloy® C-2000, C-276, C-22, B2
- Avesta 254 SMO, 904L
- Nickel
- Uranus B-6
- Incoloy / Inconel
- Monel
- Tantalum

MODEL	Min AREA (m ²)	Max AREA (m ²)
WP 20	2.40	6.10
WP 30	6.48	25.80
WP 50	27.00	81.00
WP 75	96.00	320.00
WP 150	507.00	1,270.00

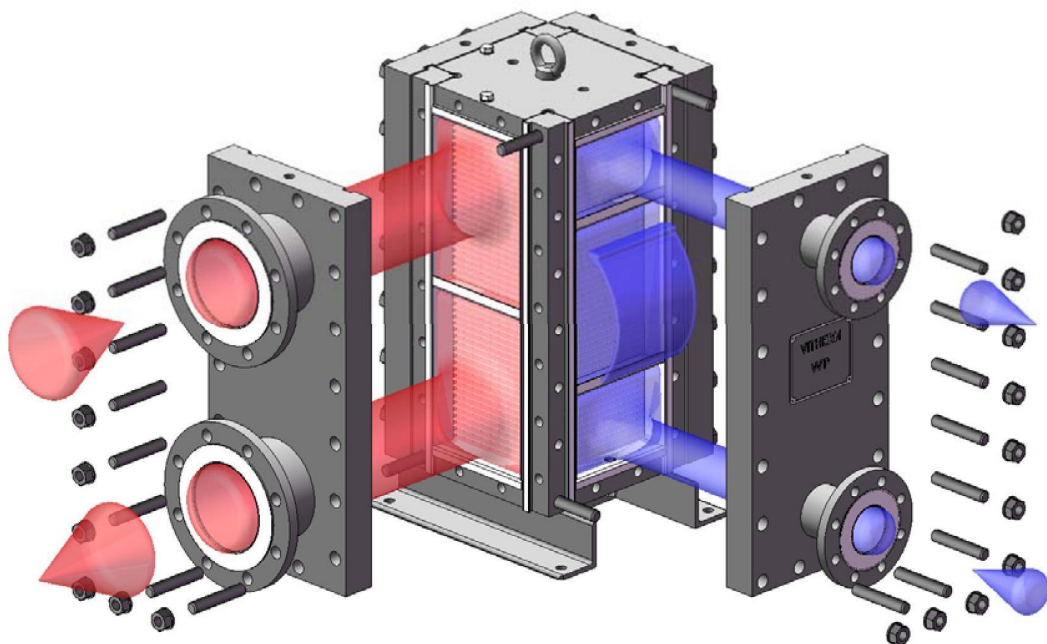

Design Pressure: Vacuum / 32 barg
Design Temperature: - 40 °C / 350 °C

OTHER PRODUCTS :



Gasketed Plate Heat Exchanger

Port Size: From 3/4" till 20"
Design Pressure: Vacuum / 20 - 25 barg
Design Temperature: -20 °C / 180 °C

Application:

- ✓ Marine Industry
- ✓ Chemical Industry
- ✓ HVAC Industry
- ✓ Oil & Gas Industry
- ✓ Food Industry



Wide Gap Welded
Plate Heat Exchanger
(without gaskets between plates)

Design Pressure: Vacuum / 35 barg
Design Temperature: 450 °C

Application:

- ✓ Ethanol Plant
- ✓ Sugar Cane Plant
- ✓ Aluminum Industry
- ✓ Steel Industry



Thermoweld
Plate & Shell
Heat Exchanger
(without gaskets between plates)

Design Pressure: Vacuum / 100 barg
Design Temperature: -200 °C / 900 °C

Application:

- ✓ Refrigeration System
- ✓ Thermal Oil System
- ✓ Chemical / Petrochemical